



注射剂用环烯烃聚合物瓶产品说明

Product Specification for Cyclic Olefin Polymer vial for injection

产品名称 Product Name	注射剂用环烯烃聚合物瓶 Cyclic Olefin Polymer vial for injection	标称容量 Nominal Capacity	2ml
文件编号 Document Code	PS-C-04	版本号 Version	03

文件批准 Document Approval

	部门 Department	姓名 Name	签字 Signature	日期 Date
起草人 Prepared by	研发部 Research and Development Department	赵自强		
审核人 Reviewed by	研发部 Research and Development Department	张鑫		
批准人 Approved by	质量部 Quality Department	孟壮		

文件批准（客户） Document Approval (Customer)

	部门 Department	签字 Signature	日期 Date
审核人 Reviewed by			
审核人 Reviewed by			
批准人 Approved by			

生产地址：四川省成都市双流区岐黄一路 1000 号天府国际生物产业加速器二期
Production address: No. 1000, Qihuang 1st Road, Shuangliu District, Chengdu, Sichuan Province
联系电话 TEL: 028-83588782-8008
Http: // www.tofflon.com

目录 contents

1. 范围 Scope	2
2. 产品描述 Components Description	2
3. 包装规范 Packing Specifications	3
3.1. 初级包装 Primary Packaging.....	3
3.2. 次级包装 Secondary Packaging.....	4
4. 产品包装、标识和储存 Packaging, Labelling, Storage	5
5. 产品符合性 Product Conformity	6
6. 质量保证 Quality Assurance	6
7. 修订历史 History.....	11
8. 附件 Drawing.....	11
8.1. 附件一：COP 西林瓶 2ml Drawing 1: Cyclic Olefin Polymer vial for injection 2ml.....	11
8.2. 附件二：西林瓶托盘 Drawing 2: TRAY 2ml	11
8.3. 附件三：产品装箱示意图 Drawing 3: Box packaging	11
8.4. 附件四：产品堆码示意图 Drawing 4: Pallet stacking	12

1. 范围 Scope

本文件适用于四川东富龙药用包装材料有限公司（简称东富龙）托盘包装的 2ml 注射剂用环烯烃聚合物瓶（简称 COP 西林瓶）。

This document applies to 2ml Cyclic Olefin Polymer vial for injection (referred to as COP vial) in TRAYs manufactured by Sichuan Tofflon Pharmaceutical Packaging Co., Ltd.

注射剂用环烯烃聚合物瓶为一次性使用、免洗免灭菌、生物相容性优异的注射剂用包装材料。相较于中硼硅玻璃管制注射剂瓶，环烯烃聚合物瓶具有与药品相容性优良、耐低温、不易破碎等优势。

Cyclic Olefin Polymer vials for injection are single-use, Ready to Use, and biocompatible packaging materials for injection. Compared with injection vials made of middle borosilicate glass tubing, Cyclic Olefin Polymer vials have the advantages such as good compatibility with drugs, resistance to low temperatures, and being less prone to breakage.

注射剂用环烯烃聚合物瓶的灌装和密封过程由制剂企业完成，相关研究由制剂企业进行。

The filling and closure of the vial is not completed by Tofflon and is not Tofflon's responsibility.

2. 产品描述 Components Description

部件 Component	材料描述 Material Description	法规标准符合性 Regulatory Reference
COP 西林瓶 COP vial	环烯烃聚合物（COP）：ZEONEX® 690R FDA DMF 号 DMF Number: 14084 供应商 Supplier: Zeon Corporation	USP<661.1> USP<87> USP<88>
托盘 TRAY	聚丙烯（PP）	ISO 10993
Tyvek® 盖材 Tyvek® Sheet	Tyvek®: PE-HD 纤维 Tyvek®: PE-HD fibbers	ISO 10993-5
Tyvek® 封纸 Tyvek® Lid	Tyvek®: PE-HD 纤维涂胶 Tyvek®: PE-HD fibbers and adhesive	ISO 10993-5
灭菌袋 Steribag	双袋：低密度聚乙烯(LDPE)与 Tyvek® Double bags: LDPE bag with Tyvek® window	ISO 10993-5
灭菌 Sterilization	环氧乙烷灭菌 EtO Sterilization	GB 18279 ISO 11135

3. 包装规范 Packing Specifications

3.1. 初级包装 Primary Packaging

托盘 TRAY			
	序号 ID	描述 Description	备注 Note
	1	托盘 TRAY	见附件二 Drawing 2
	2	COP 西林瓶 COP vial	见附件一 Drawing 1
	3	Tyvek® 盖材 Tyvek® Sheet	-
	4	Tyvek® 封纸 Tyvek® Lid	-
	技术参数 Technical Parameters		
每托盘产品数量 (个) Vials/ TRAY		228	
每托盘产品重量 (g) Gross weight (g)		973	
双层灭菌袋包装 Double Steribags packaging			
	序号 ID	描述 Description	备注 Note
	5	第一个灭菌袋 1st Steribag	-
	6	第二个灭菌袋 2nd Steribag	-

3.2. 次级包装 Secondary Packaging

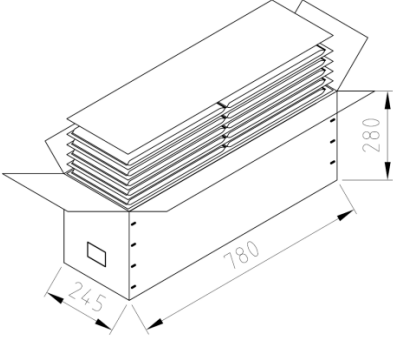
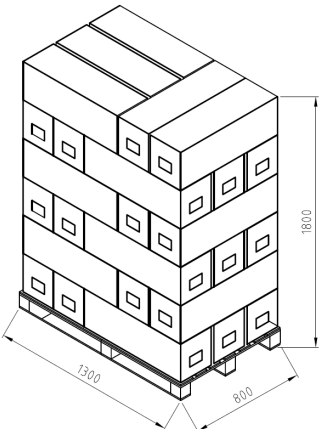
纸箱包装 Box packaging		
	技术参数 Technical parameters	
	纸箱尺寸（长*宽*高（mm）） Overall dimension (Length*width*height) (mm)	780 * 245 * 280
	每层的托盘数量（盒） TRAYs per layer (pcs)	2
	每箱的层数（层） Layers per box (pcs)	5
	托盘总数（盒） Tubs per box (pcs)	10
	瓶子总数（只） Total quantity of vials per box (pcs)	2280
	每箱重量（kg） Gross weight (kg)	11.6
	产品装箱和堆码示意图见附件三、附件四 The drawings of product box packaging and pallet packaging are shown in Drawing 3 and Drawing 4.	
	技术参数 Technical Parameters	
	运输装载尺寸（长*宽*高（mm））P allet dimension (Length*width*height) (mm)	1300 * 800 * 1800
	每层的包装纸箱数量（箱） Boxes per layer (pcs)	5
	每托盘层数（层） Layers per pallet (pcs)	6
	包装纸箱总数（箱） Boxes per pallet (pcs)	30
	产品总数（只） Vials per pallet (pcs)	68400
	每托盘重量（kg） Gross Weight (kg)	364

4. 产品包装、标识和储存 Packaging, Labelling, Storage

为保护产品免受污染和损害，本产品采用托盘及双层灭菌袋包装，并在 C 级背景下的 A 级洁净环境中注塑、吹塑和内包装。托盘、封纸和双层灭菌袋形成无菌屏障系统。内包装完成后，产品装入五层瓦楞纸箱，每层产品之间均安装隔板，产品托盘堆码完成后，各边角均采用缠绕膜保护，从而更好地确保产品在运输和储存过程中不发生破坏和污染。

To protect the product from contamination and damage, this product is packaged in TRAYs and double steribags, and the process of injecting, blowing and primary packaging are carried out in Class A clean environment in Class C background. TRAY, Tyvek Lid, and steribag form the sterile barrier system. After the primary packaging, the product is loaded into a five-layer corrugated box, and after the product pallet is stacked, all corners are protected by stretch film, so as to better ensure that the product is not damaged and polluted during transportation and storage.

本产品标识信息如下：Packaging identification may include the following information:

标识信息 Identification Information	灭菌袋 steribag	纸箱 Box
供应商名称 Supplier Name	+	+
产品名称 Product Name	+	+
产品批号 Batch Number	+	+
产品数量 Quantity	+	+
生产日期 Manufacturing Date	+	+
有效期至 Expiry Date	+	+
灭菌方式 Type of sterilization	+	+

注：“+”表示标识该信息，“-”表示未标识该信息。

Note: "+" indicates that the information is identified, and "-" means that the information is not identified.

本产品应在室温下（10°C-30°C）储存。

This product should be stored at room temperature (10°C-30°C).

我公司按照 T/CNPPA 3017-2021《塑料和橡胶类药包材自身稳定性研究指南》对本产品进行长期试验和加速试验，以评估产品的自身稳定性，暂定本产品有效期为 3 年。

Tofflon conducts long-term tests and accelerated tests on this product in accordance with T/CNPPA 3017-2021 "Guidelines for Self-Stability Research of Plastic and Rubber Pharmaceutical Packaging Materials" to evaluate the self-stability of the product. The shelf life of this product is tentatively set at 3 years.

5. 产品符合性 Product Conformity

我公司按照中国药典指导原则 9624、YBB00022002-2015《聚丙烯输液瓶》和 USP<661.1>等设定本产品质量标准并进行检验放行。

Tofflon sets the product quality standards and inspects and releases the product in accordance with the guideline of the Chinese Pharmacopoeia 9624, YBB00022002-2015 "PP Infusion Bottles" and USP<661>.

本产品生物学评价按照 USP<87>、USP<88>和中国药典 9651《药包材生物学评价与试验选择指导原则》等指导原则和标准执行。

The biological evaluation of this product is carried out in accordance with USP<87>, USP<88> and Chinese Pharmacopoeia 9651 "Guiding Principles for Biological Evaluation and Test Selection of Pharmaceutical Packaging Materials" and other guiding principles and standards.

本产品密封性研究按照中国药典 9650《药品包装系统密封性研究指导原则》、《化学药品注射剂包装系统密封性研究技术指南（试行）》和 USP<1207>执行。

The container-closure integrity test of this product is carried out in accordance with the Chinese Pharmacopoeia 9650 "Guiding Principles for the Tightness Research of Drug Packaging Systems", "Technical Guidelines for the Tightness Research of Chemical Injection Packaging Systems (Trial)" and USP<1207>.

本产品相容性研究按照《化学药品注射剂与塑料包装材料相容性研究技术指导原则（试行）》及 ICH Q3D 执行。

The compatibility study of this product is carried out in accordance with the "Technical Guidelines for the Study of the Compatibility of Chemical Injections and Plastic Packaging Materials (Trial)" and ICH Q3D.

6. 质量保证 Quality Assurance

我公司按照《药品生产质量管理规范》、《药包材生产质量管理规范》和 ISO 15378 药包材质量管理体系要求等法规标准建立、保持并持续改进我们的质量管理体系，以确保持续提供符合规定且质量稳定的产品和服务。

Tofflon establishes, maintains and continuously improves our quality management system in accordance with regulations and standards such as "Good Manufacturing Practice for Pharmaceutical Manufacturing", "Good Manufacturing Practice for Pharmaceutical Packaging Materials" and ISO 15378 *Primary packaging materials for medicinal products-Particular requirements for the application of ISO 9001:2015, with reference to good manufacturing practice(GMP)* to ensure that we continue to provide products and services that meet the requirements and have controllable quality.

本产品符合以下法规及标准要求：

This product complies with the following regulations and standards:

- 中国药典 9624 药品包装用塑料材料和容器指导原则

- ChP 9624 Guideline for plastic packaging system and components for pharmaceutical packaging
- USP<661.1> Plastic Materials of Construction
- YBB00022002-2015 聚丙烯输液瓶
- YBB00022002-2015 PP Infusion Bottles
- USP<87> Biological Reactivity, In Vitro
- USP<88> Biological Reactivity, In Vivo
- 中国药典 9651 《药包材生物学评价与试验选择指导原则》
- ChP 9651 Guiding Principles for Biological Evaluation and Test Selection of Pharmaceutical Packaging Materials

我公司采取以下措施，从设计上控制本产品质量：

Tofflon takes the following measures to control the quality of this product from the design:

- 产品采用模塑工艺，更好地保证产品尺寸稳定性；
- The product adopts the molding process to ensure the dimensional stability of the product as much as possible;
- 产品注塑、吹塑至内包装工序在 C 级背景下的 A 级洁净环境中进行，最大限度地控制产品微粒、细菌内毒素和微生物污染；
- The process from injecting, blowing to primary packaging process are carried out in a Class A clean environment in Class C background to maximize the control of product particles, bacterial endotoxins and microbial contamination;
- 生产线上配置了多个在线外观检测装置，第一时间剔除不良品；
- The production line is equipped with multiple appearance inspection devices to reject defective products at the first time;
- 采用全自动运线，杜绝人为差错。
- Automatic transportation line is adopted to eliminate human error.

我公司按照中国药典《药包材检验规则指导原则》和 GB/T 2828 (idt. : ISO 2859) 制定本产品检验项目的检验规则和质量水平，如下表。

Tofflon formulate the inspection rules and Acceptance Quality Limit of the product inspection items in accordance with the ChP "Guiding Principles for the Inspection Rules of Pharmaceutical Packaging Materials" and GB/T 2828 (idt. :ISO 2859), as shown in the following table.

检验项目 Items	接受标准 Acceptance criteria	缺陷等级分 类 Defect grade c lassification	是否批 检验 Batch ins pection?	检验 水平 Inspecti on level	接收质量 限 (AQL)
外观 Appearance	应无裂缝和裂痕，本品与注射液接触的表面应清洁、无微粒、无异物、毛边、毛刺、塑流、缺损，外表面应无斑点、污点、擦痕、划	随机性缺陷 A 类 Random Def ect A	是 Yes	I	1.5

检验项目 Items	接受标准 Acceptance criteria	缺陷等级分 类 Defect grade c lassification	是否批 检验 Batch ins pection?	检验 水平 Inspecti on level	接收质量 限 (AQL)
	痕。 There should be no cracks or cracks. The surface of this product in contact with the injection should be clean, free of particles, foreign objects, burrs, plastic flow, and defects. The outer surface should be free of spots, stains, scratches, and scratches, with sufficient transparency and without printing defects that affect use.				
尺寸、重量和满口容量 Dimension, weight and brimful capacity	应符合产品图纸要求 It should be in accordance with Quality Standard	随机性缺陷 A类 Random Defect A	是 Yes	S-3	1.5
鉴别 Identification	应与本品典型图谱基本一致 It should be basically consistent with the typical pattern of this product	系统性缺陷 Systemic Defect	否 No	N/A	N/A
抗跌落 Drop resistance	应不得破裂和泄漏 It should not break or leak	随机性缺陷 B类 Random Defect B	是 Yes	S-3	1.5
透明度 Transparency	应能与对照瓶区分 It should be able to distinguish from the control bottle	随机性缺陷 A类 Random Defect A	是 Yes	S-3	1.5
水蒸气透过量 Water vapor permeability	每个注射剂瓶减少的重量不得过 0.1% The weight reduction of each vial shall not exceed 0.1%	随机性缺陷 A类 Random Defect A	是 Yes	S-3	1.5
炽灼残渣 Ignition residue	≤0.05%	系统性缺陷 Systemic Defect	否 No	N/A	N/A
金属元素 Metal elements	铜、镉、铬、铅、锡、钡均不得过百万分之三 Copper, cadmium, chromium, lead, tin, and barium shall not exceed 3ppm	系统性缺陷 Systemic Defect	否 No	N/A	N/A
环氧乙烷残留量 Residual amount	≤5μg/个 ≤5μg/vial	随机性缺陷 A类 Random Def	是 Yes	N/A	N/A

检验项目 Items	接受标准 Acceptance criteria	缺陷等级分 类 Defect grade c lassification	是否批 检验 Batch ins pection?	检验 水平 Inspecti on level	接收质量 限 (AQL)
unt of ethylen e oxide		ect A			
不溶性微粒 Insoluble part icles	≥10µm 的微粒: 不得过 60 粒/个; ≥25µm 的微粒: 不得过 6 粒/个。 ≥10µm: NMT 60/vial; ≥25µm: NMT6/vial	随机性缺陷 A 类 Random Def ect A	是 Yes	N/A	N/A
细菌内毒素 Bacterial end otoxin	<0.25EU/ml	随机性缺陷 A 类 Random Def ect A	是 Yes	N/A	N/A
无菌 Sterile	应符合规定 Be compliance	随机性缺陷 A 类 Random Def ect A	是 Yes	N/A	N/A

溶出物试验 Extractables test (ChP)

检验项目 Items	接受标准 Acceptance criteria	缺陷等级分 类 Defect grade c lassification	是否批 检验 Batch ins pection?	检验 水平 Inspecti on level	接收质量 限 (AQL)
澄 清 度 与 颜 色 Clarity and col or	供试液应澄清, 如显浑浊, 与 0.5 号浊度标准液比较, 不得更浓。供 试液应无色 The solution should be clear and colo rless; The test solution should be cle ar, any turbidity produced should be not more intense than turbidity stan dard solution No.0.5	系统性缺陷 Systemic De fect	否 No	N/A	N/A
pH	5.0~7.0				
吸光度 Absorbance	220~240nm 间最大吸收值不得过 0.08; 241~350nm 间最大吸收值 不得过 0.05。 The maximum absorption value betw een 220 and 240nm shall not exceed 0.08; The maximum absorption valu e between 241-350nm shall not exce ed 0.05.				
易氧化物 Oxidizable sub stance	供试液与对照液消耗硫代硫酸钠滴 定液 (0.01mol/L) 体积之差不得 过 1.5mL The difference in volume between th				

检验项目 Items	接受标准 Acceptance criteria	缺陷等级分 类 Defect grade c lassification	是否批 检验 Batch ins pection?	检验 水平 Inspecti on level	接收质量 限 (AQL)
	e consumed sodium thiosulfate titrant (0.01mol/L) of the test solution and the control solution should not exceed 1.5mL				
不挥发物 Nonvolatile matter	供试液与空白液遗留残渣之差不得 过 2.5mg The difference between the residue left by the test solution and the blank solution should not exceed 2.5mg				
重金属 Heavy metals	不得过百万分之一 ≤1ppm				
铵离子 Ammonium ion	与对照液目视比色, 不得更深 (0.00008%) Compared with the control solution visually, it should not be darker (0.00008%)				
金属离子 Metal ions	钡离子、铜离子、铅离子、铬离子: 不得过百万分之一; 镉离子、锡离子: 不得过千万分之一; 铝离子: 不得过千万分之零点五 Barium ions, Copper ions, Lead ions, Chromium ions: NMT 1ppm; cadmium ions, Tin ions: NMT 0.1 ppm; Aluminium ions: NMT 0.05 ppm				
总有机碳 Total organic carbon	供试液与空白液中 TOC 含量之差应 ≤5mg/L The difference in TOC content between the test solution and the blank solution should be ≤ 5mg/L				

理化性能 (USP) Physicochemical Tests (USP)

检验项目 Items	接受标准 Acceptance criteria	缺陷等级分 类 Defect grade c lassification	是否批 检验 Batch ins pection?	检验 水平 Inspecti on level	接收质量 限 (AQL)
重金属 Heavy metals	不得过百万分之一 ≤1ppm				
不挥发物 Nonvolatile matter	供试液与空白液遗留残渣之差不得 过 15mg The difference between the residue left by the test solution and the blank	N/A	N/A	N/A	N/A

检验项目 Items	接受标准 Acceptance criteria	缺陷等级分 类 Defect grade c lassification	是否批 检验 Batch ins pection?	检验 水平 Inspecti on level	接收质量 限 (AQL)
	solution should not exceed 15mg				

理化性能 (EP) Physicochemical Tests (EP)

检验项目 Items	接受标准 Acceptance criteria	缺陷等级分 类 Defect grade c lassification	是否批 检验 Batch insp ection?	检验水 平 Inspecti on level	接收质 量限 (A QL)
供试液外观 Appearance	供试液应澄清无色 The test solution should be clear and colorless	N/A	N/A	N/A	N/A
酸碱度 Acidity/ alkalinity	应符合质量标准要求 See Test method				
吸光度 Absorbance	220~360nm 间最大吸收值不得过 0.2 The maximum absorption value between 220 and 360nm shall not exceed 0.2				
易氧化物 Oxidizable substance	供试液与对照液消耗硫代硫酸钠滴定液 (0.01mol/L) 体积之差不得过 1.5mL The difference in volume between the consumed sodium thiosulfate titrant (0.01mol/L) of the test solution and the control solution should not exceed 1.5mL				

7. 修订历史 History

版本号 Version	修订日期 Date	变更描述 Description
01	2024.05.03	新文件 New document
02	2024.10.28	增加 USP、EP 项目 Add USP and EP items
03	2025.08.05	增加英文版本 Add English translation

8. 附件 Drawing

- 8.1. 附件一：COP 西林瓶 2ml Drawing 1: Cyclic Olefin Polymer vial for injection 2ml
- 8.2. 附件二：西林瓶托盘 Drawing 2: TRAY 2ml
- 8.3. 附件三：产品装箱示意图 Drawing 3: Box packaging

版本	修订标记	修订说明	修订人	修订日期

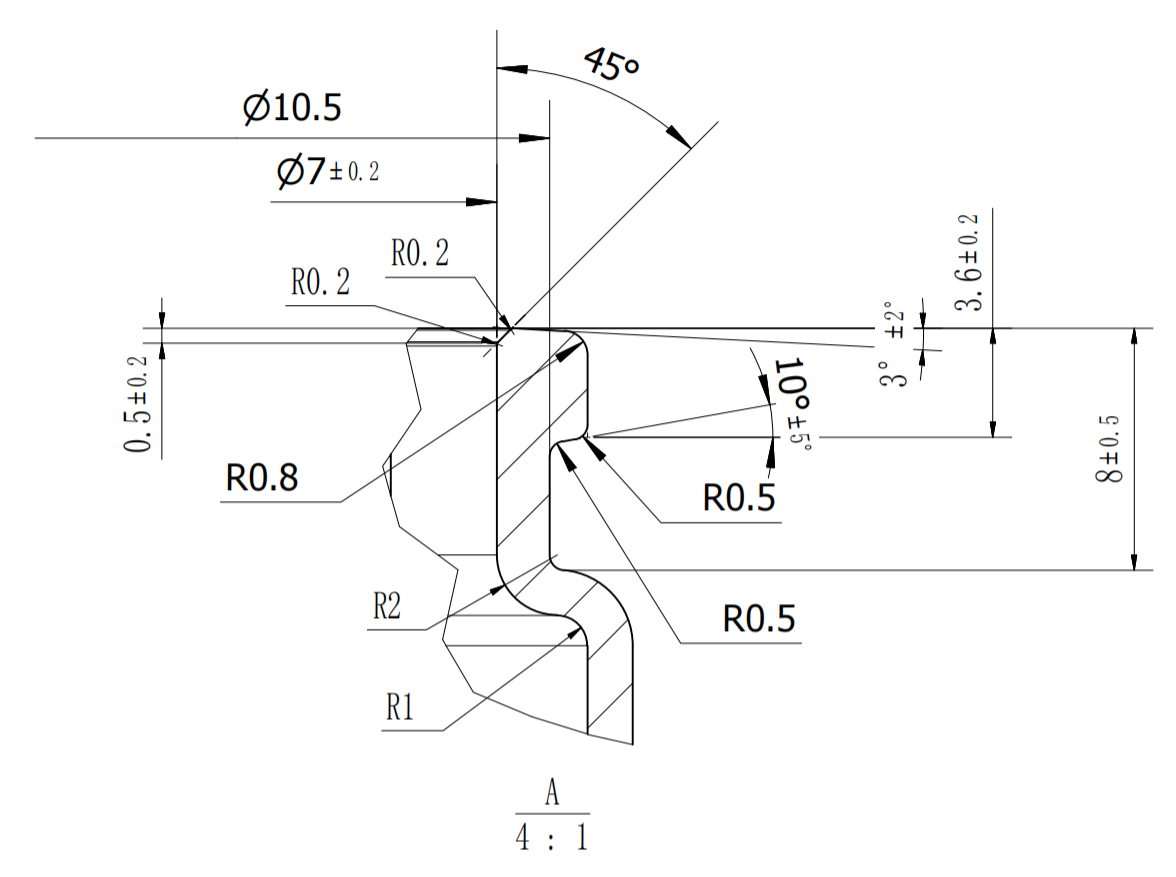
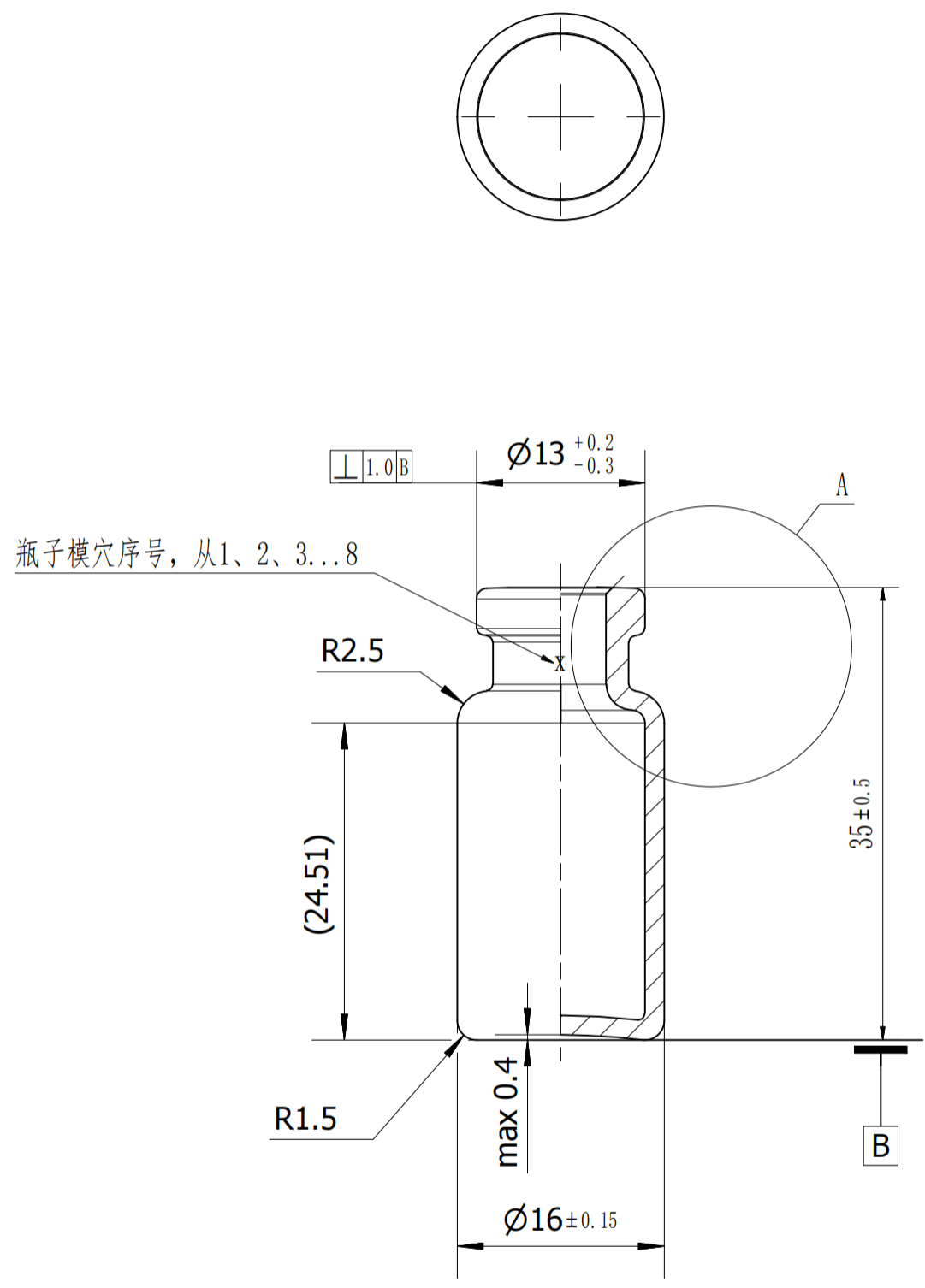

- 技术参数:
- 外形尺寸参考ISO 8362-1: 2018 玻璃管制注射剂瓶2R的要求。
 - 瓶子刻凸序号, 大小3.5, 字体Arial
 - 瓶子内、外表面粗糙度达到镜面效果
 - 满口容量3.5ml

Tofflon 东富龙		此图纸版权属于东富龙所有, 对未经许可擅自拷贝、使用者, 本公司保留追究其法律责任的权利。 THIS DRAWING IS COPYRIGHT. IT MUST NOT BE COPIED, REPRODUCED OR OTHERWISE MADE USE OF WITHOUT THE TOFFLON'S WRITTEN PERMISSION.		
标题/TITLE:		页/SHEET: 1 共/OF: 1	图幅/SIZE: A3	
COP西林瓶 (2R)		图号/DWG: TZ-TFL-1003-02		版本/REV: 02
客户名/CUSTOMER:		项目号/PROJECT NUMBER:		
设计/DESIGNED: WL	日期/DATE: 2022/12/15	质量/MASS:		未注明公差表 TOLERANCED UNLESS OTHERWISE NOTED
校核/CHECKED: SQ	日期/DATE: 2022/12/15	比例/SCALE: 2 : 1		
审核/APPROVED: ZJW	日期/DATE: 2022/12/15	材料/MATERIAL: COP	机加工 MACHINING GB/T 1804-m GB/T 1184-K	焊接 WELDING GB/T 19804-B GB/T 19804-F
			钣金 SHEET METAL GB/T 15055-m	

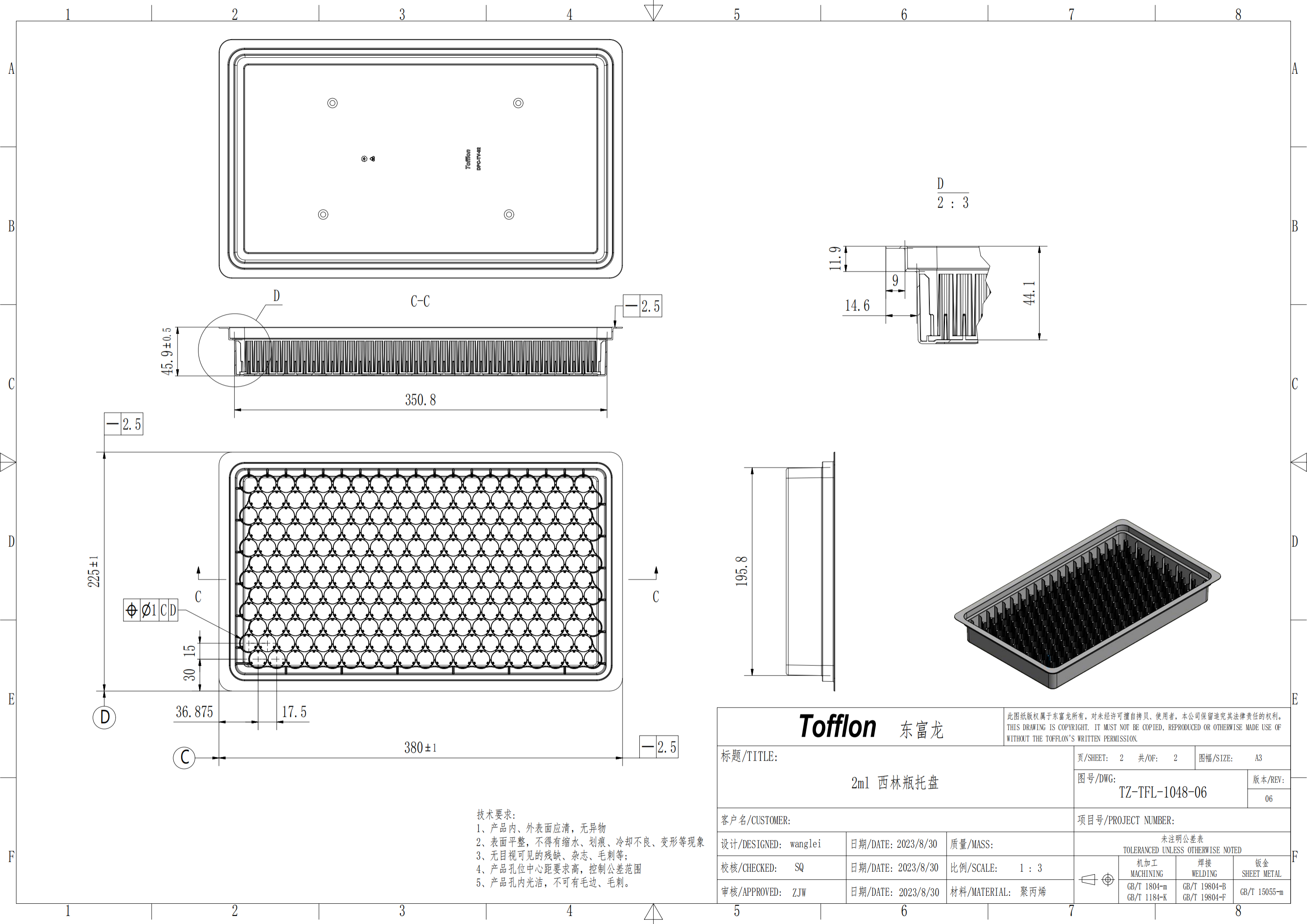

$\frac{D}{2} : 3$

-2.5

-2.5

225 ± 1

$\phi 1$ CD

30 15

36.875

17.5

380 ± 1

-2.5

195.8

- 技术要求:
- 1、产品内、外表面应清, 无异物
 - 2、表面平整, 不得有缩水、划痕、冷却不良、变形等现象
 - 3、无目视可见的残缺、杂质、毛刺等;
 - 4、产品孔位中心距要求高, 控制公差范围
 - 5、产品孔内光洁, 不可有毛边、毛刺。

Tofflon 东富龙

此图纸版权属于东富龙所有, 对未经许可擅自拷贝、使用者, 本公司保留追究其法律责任的权利。
THIS DRAWING IS COPYRIGHT. IT MUST NOT BE COPIED, REPRODUCED OR OTHERWISE MADE USE OF WITHOUT THE TOFFLON'S WRITTEN PERMISSION.

标题/TITLE:		页/SHEET: 2 共/OF: 2		图幅/SIZE: A3	
2ml 西林瓶托盘		图号/DWG: TZ-TFL-1048-06		版本/REV: 06	
客户名/CUSTOMER:		项目号/PROJECT NUMBER:			
设计/DESIGNED: wanglei	日期/DATE: 2023/8/30	质量/MASS:		未注明公差表 TOLERANCED UNLESS OTHERWISE NOTED	
校核/CHECKED: SQ	日期/DATE: 2023/8/30	比例/SCALE: 1 : 3		机加工 MACHINING	焊接 WELDING
审核/APPROVED: ZJW	日期/DATE: 2023/8/30	材料/MATERIAL: 聚丙烯		钣金 SHEET METAL	
		GB/T 1804-m GB/T 1184-K	GB/T 19804-B GB/T 19804-F	GB/T 15055-m	

版本	修订标记	修订说明	修订人	修订日期

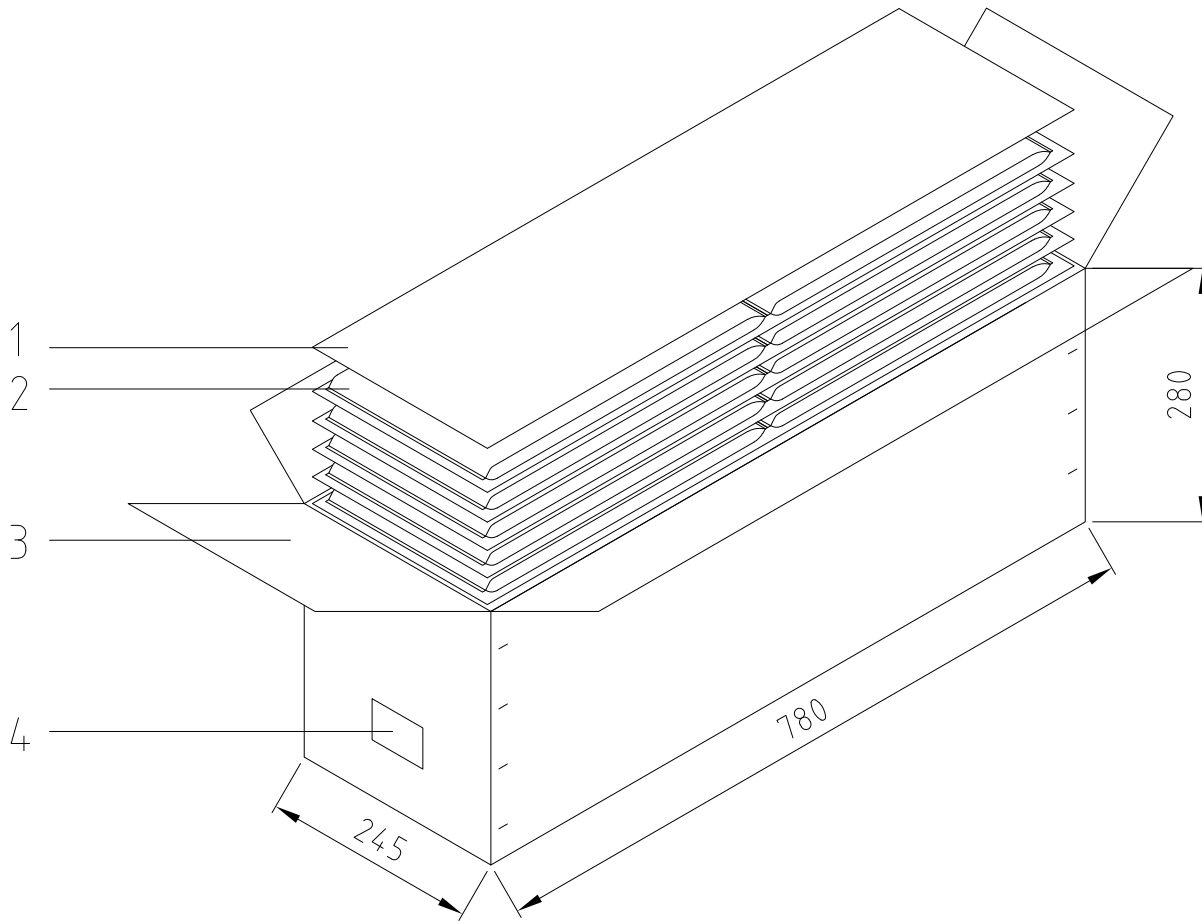

序号	详细信息
1	隔板
2	双层呼吸袋包装并封口的产品
3	五层瓦楞纸箱
4	纸箱标签

Tofflon 东富龙		此图纸版权属于东富龙所有，对未经许可擅自拷贝、使用者，本公司保留追究其法律责任的权利。 THIS DRAWING IS COPYRIGHT. IT MUST NOT BE COPIED, REPRODUCED OR OTHERWISE MADE USE OF WITHOUT THE TOFFLON'S WRITTEN PERMISSION.		
标题/TITLE: 托盘包装产品装箱示意图(10)		页/SHEET: 1 共/OF: 1	图幅/SIZE: A4_CN	
客户名/CUSTOMER:		项目号/PROJECT NUMBER:		
设计/DESIGNED: ZX	日期/DATE: 2024.04.25	质量/MASS:	未注明公差表 TOLERANCED UNLESS OTHERWISE NOTED	
审核/CHECKED:	日期/DATE:	比例/SCALE: 2:25	MACHINING 机加工	WELDING 焊接
审核/APPROVED: SYT	日期/DATE: 2024.04.25	材料/MATERIAL: N/A	GB/T 1804-m GB/T 1184-K	SHEET METAL 钣金 GB/T 19804-B GB/T 19804-F
			GB/T 15055-m	

1	2	3	4
版本	修订标记	修订说明	修订人

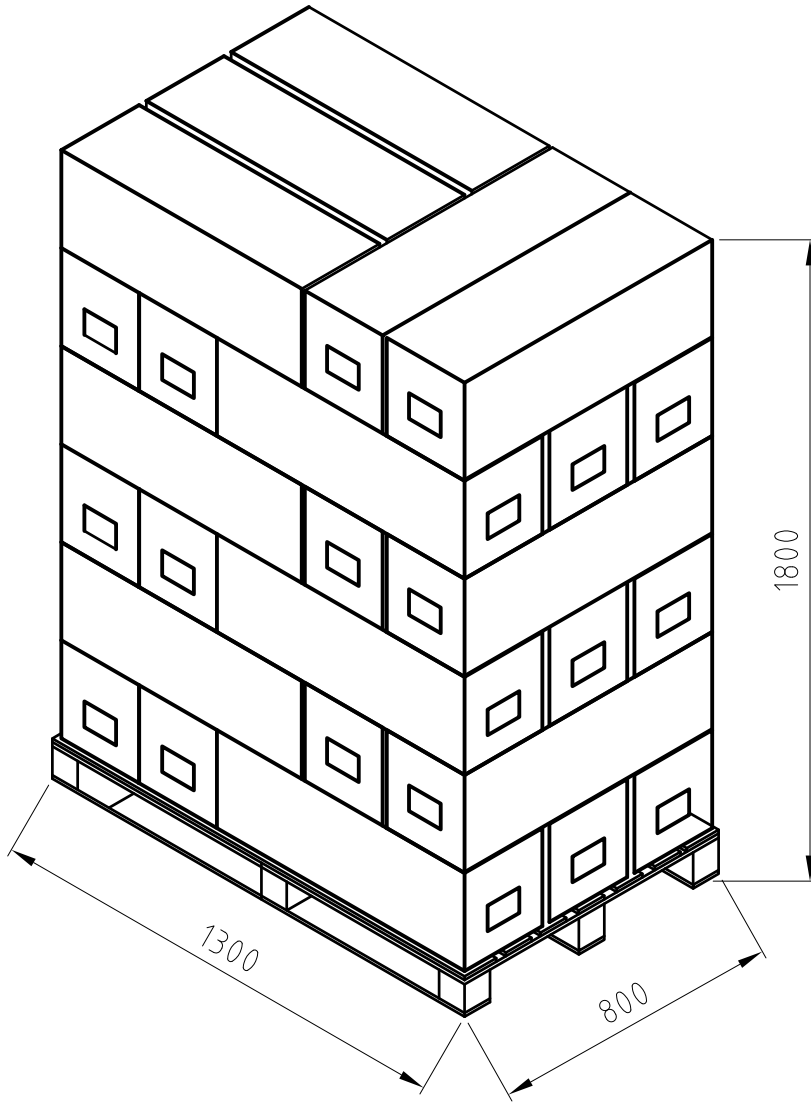

Tofflon 东富龙		此图纸版权属于东富龙所有，对未经许可擅自拷贝、使用者，本公司保留追究其法律责任的权利。 THIS DRAWING IS COPYRIGHT. IT MUST NOT BE COPIED, REPRODUCED OR OTHERWISE MADE USE OF WITHOUT THE TOFFLON'S WRITTEN PERMISSION.		
标题/TITLE: 托盘包装产品堆码示意图		页/SHEET: 1 共/OF: 1	图幅/SIZE: A4_CN	
客户名/CUSTOMER:		项目号/PROJECT NUMBER:		
设计/DESIGNED: ZX	日期/DATE: 2024.04.25	质量/MASS:	未注明公差表 TOLERANCED UNLESS OTHERWISE NOTED	
审核/CHECKED:	日期/DATE:	比例/SCALE: 1:20	MACHINING 机加工	WELDING 焊接
审核/APPROVED: SYT	日期/DATE: 2024.04.25	材料/MATERIAL: N/A	GB/T 1804-m GB/T 1184-K	SHEET METAL 钣金 GB/T 19804-B GB/T 19804-F
			GB/T 15055-m	