

## 笔式注射器用卡式瓶系统产品说明

# Product Specification for Cartridge System for Pen-injectors

产品名称 Product Name	笔式注射器用卡式瓶系统 Cartridge system for Pen-injectors	标称容量 Nominal Capacity	3ml
文件编号 Document Code	PS-K-01	版本号 Version	03

### 文件批准 Document Approval

	部门 Department	姓名 Name	签字 Signature	日期 Date
起草人 Prepared by	研发部 Research and Development Department	赵自强		
审核人 Reviewed by	研发部 Research and Development Department	张鑫		
批准人 Approved by	质量部 Quality Department	孟壮		

### 文件批准（客户） Document Approval (Customer)

	部门 Department	签字 Signature	日期 Date
审核人 Reviewed by			
审核人 Reviewed by			
批准人 Approved by			

生产地址：四川省成都市双流区岐黄一路 1000 号天府国际生物产业加速器二期

Production address: No. 1000, Qihuang 1st Road, Shuangliu District, Chengdu, Sichuan Province

联系电话 TEL: 028-83588782-8008

Http: // www.tofflon.com

## 目录 contents

1. 范围 Scope.....	2
2. 产品描述 Components Description .....	2
3. 包装规范 Packing Specifications .....	3
3.1. 初级包装 Primary Packaging.....	3
3.2. 次级包装 Secondary Packaging.....	4
4. 产品包装、标识和储存 Packaging, Labelling, Storage .....	5
5. 产品符合性 Product Conformity.....	6
6. 质量保证 Quality Assurance .....	6
7. 修订历史 History.....	12
8. 附件 Drawing.....	12
8.1. 附件一：笔式注射器用卡式瓶系统（组装铝盖） Drawing 1: Cartridge with Cap 3ml.....	12
8.2. 附件二：卡式瓶巢板 3ml Drawing 2: Nest 3ml.....	12
8.3. 附件三：巢盒 Drawing 3: Tub.....	12
8.4. 附件四：产品装箱示意图 Drawing 4: Box packaging .....	12
8.5. 附件五：产品堆码示意图 Drawing 5: Pallet stacking .....	12
8.6. 附件六：笔式注射器用硼硅玻璃套筒 3ml Drawing 6: Glass Barrel 3ml .....	12
8.7. 附件七：笔式注射器用含垫片铝盖 Drawing 7: Aluminium Cap with Liner .....	12
8.8. 附件八：笔式注射器用溴化丁基橡胶活塞 Drawing 8: Plunger .....	12

## 1. 范围 Scope

本文件适用于四川东富龙药用包装材料有限公司（以下简称东富龙）生产的笔式注射器用硼硅玻璃套筒生产的 3ml 笔式注射器用卡式瓶系统（简称卡式瓶）。

This document applies to 3ml Cartridge system for pen-injectors (referred to as cartridge) manufactured by Sichuan Tofflon Pharmaceutical Packaging Co., Ltd.

笔式注射器用卡式瓶系统为一次性使用、免洗免灭菌、无热原的注射剂用包装材料。

Cartridge system for pen-injectors are single-use, Ready to Use packaging materials for injections.

笔式注射器用卡式瓶系统的灌装和密封过程由制剂企业完成，相关研究由制剂企业进行。

The filling and closure of the cartridge is not completed by Tofflon and is not Tofflon's responsibility

## 2. 产品描述 Components Description

部件 Component	材料描述 Material Description	法规标准符合性 Regulatory Reference
笔式注射器用 硼硅玻璃套筒 Cartridge barrel	中硼硅玻璃 borosilicate glass barrel for pen-injectors	ISO 13926-1 YBB00132004-2015 中国药典 9622 ChP 9622 USP<660> EP 3.2.1
笔式注射器用 溴化丁基橡胶 活塞 Plunger	溴化丁基橡胶 Bromobutyl rubber	USP<381> EP 3.2.9 中国药典 9623 ChP 9623 YBB00162004-2015
含垫片铝盖 Al Cap with liner	铝盖材质：铝 垫片材质：溴化丁基橡胶和异戊二烯橡胶 Al cap: Al Liners: Bromobutyl rubber/Polyisoprene rubber	USP<381> EP 3.2.9 中国药典 9623 ChP 9623 YBB00162004-2015
润滑剂 Lubrication	二甲基硅油乳液 Dimethicone	ChP USP EP 9.6
巢板 Nest	聚丙烯（PP）	ISO 10993
巢盒 Tub	高抗冲聚苯乙烯（HIPS）	EN71-3:2013 + A1:2014 + A2:2017 + A3:2018 + A4:2019 21 CFR 177.1640
Tyvek®盖材 Tyvek® Sheet	Tyvek®: PE-HD 纤维 Tyvek®: PE-HD fibbers	ISO 10993-5

Tyvek®封纸 Tyvek® Lid	Tyvek®: PE-HD 纤维, 涂胶 Tyvek®: PE-HD fibbers and adhesive	ISO 10993-5
灭菌袋 Steribag	双袋: 低密度聚乙烯(LDPE)与 Tyvek® Double bags: LDPE bag with Tyvek® window	ISO 10993-5
灭菌 Sterilization	环氧乙烷灭菌 EtO Sterilization	GB 18279 ISO 11135

### 3. 包装规范 Packing Specifications

#### 3.1. 初级包装 Primary Packaging

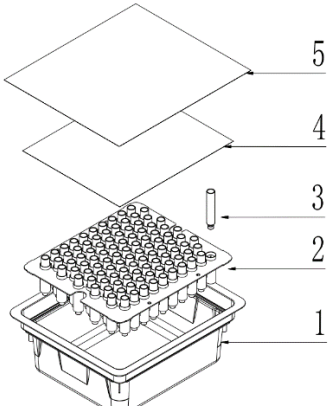
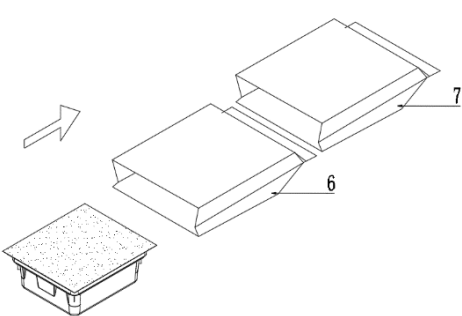
巢盒巢板 Nest Tub			
	序号 ID	描述 Description	备注 Note
	1	巢盒 Tub	见附件三 Drawing 3
	2	巢板 Nest	见附件二 Drawing 2
	3	玻璃卡式瓶 Glass cartridge	见附件一 Drawing 1
	4	Tyvek®盖材 Tyvek® Sheet	-
	5	Tyvek®封纸 Tyvek® Lid	-
	技术参数 Technical Parameters		
	每巢盒产品数量 (个) Cartridges/ Nest		100
	每巢盒产品重量 (g) Gross weight (g)		934
	双层灭菌袋包装 Double Steribags packaging		
	序号 ID	描述 Description	备注 Note
	6	第一个灭菌袋 1st Steribag	-
	7	第二个灭菌袋 2nd Steribag	-

## 3.2. 次级包装 Secondary Packaging

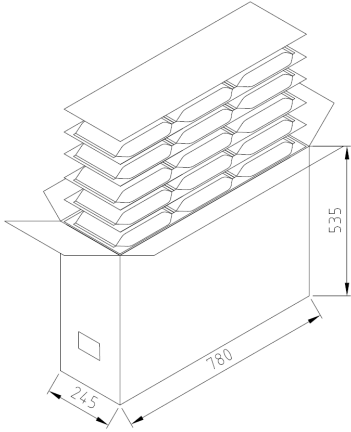
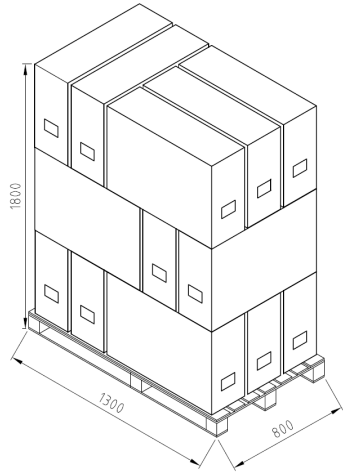
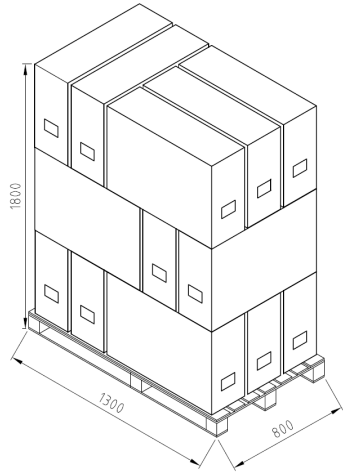
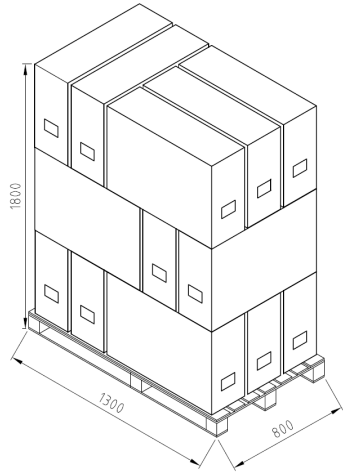
纸箱包装 Box packaging																		
	技术参数 Technical parameters																	
	纸箱尺寸 (长*宽*高 (mm)) Overall dimension (Length*width*height) (mm)	780 * 245 * 535																
	每层的巢盒数量 (盒) Tubs per layer (pcs)	3																
	每箱的层数 (层) Layers per box (pcs)	5																
	巢盒总数 (盒) Tubs per box (pcs)	15																
	瓶子总数 (只) Total quantity of Cartridges per box (pcs)	1500																
	每箱重量 (kg) Gross weight (kg)	15.4																
	<table border="1"> <thead> <tr> <th colspan="3">技术参数 Technical Parameters</th> </tr> </thead> <tbody> <tr> <td rowspan="7">  </td> <td colspan="2">运输装载尺寸 (长*宽*高 (mm)) Pallet dimension (Length*width*height)(mm)</td> </tr> <tr> <td>每层的包装纸箱数量 (箱) Boxes per layer (pcs)</td> <td>5</td> </tr> <tr> <td>每托盘层数 (层) Layers per pallet (pcs)</td> <td>3</td> </tr> <tr> <td>包装纸箱总数 (箱) Boxes per pallet (pcs)</td> <td>15</td> </tr> <tr> <td>产品总数 (只) Cartridges per pallet (pcs)</td> <td>22500</td> </tr> <tr> <td>每托盘重量 (kg) Gross Weight (kg)</td> <td>241</td> </tr> </tbody> </table>			技术参数 Technical Parameters				运输装载尺寸 (长*宽*高 (mm)) Pallet dimension (Length*width*height)(mm)		每层的包装纸箱数量 (箱) Boxes per layer (pcs)	5	每托盘层数 (层) Layers per pallet (pcs)	3	包装纸箱总数 (箱) Boxes per pallet (pcs)	15	产品总数 (只) Cartridges per pallet (pcs)	22500	每托盘重量 (kg) Gross Weight (kg)
技术参数 Technical Parameters																		
	运输装载尺寸 (长*宽*高 (mm)) Pallet dimension (Length*width*height)(mm)																	
	每层的包装纸箱数量 (箱) Boxes per layer (pcs)	5																
	每托盘层数 (层) Layers per pallet (pcs)	3																
	包装纸箱总数 (箱) Boxes per pallet (pcs)	15																
	产品总数 (只) Cartridges per pallet (pcs)	22500																
	每托盘重量 (kg) Gross Weight (kg)	241																
	产品装箱和堆码示意图见附件四、附件五 The drawings of product box packaging and pallet packaging are shown in Drawing 4 and Drawing 5.																	

## 4. 产品包装、标识和储存 Packaging, Labelling, Storage

为保护产品免受污染和损害，本产品采用巢盒巢板及双层灭菌袋包装，并在 C 级背景下的 A 级洁净环境中轧盖和内包装。巢盒、封纸和双层灭菌袋形成无菌屏障系统。内包装完成后，产品装入五层瓦楞纸箱，每层产品之间均安装隔板，产品托盘堆码完成后，各边角均采用缠绕膜保护，从而更好地确保产品在运输和储存过程中不发生破坏和污染。

To protect the product from contamination and damage, this product is packaged in nests, tubs and double steribags, and the process of capping and primary packaging are carried out in Class A clean environment in Class C background. Tub, Tyvek Lid, and steribag form the sterile barrier system. After the primary packaging, the product is loaded into a five-layer corrugated box, and after the product pallet is stacked, all corners are protected by stretch film, so as to better ensure that the product is not damaged and polluted during transportation and storage.

本产品标识信息如下：Packaging identification may include the following information:

标识信息 Identification Information	灭菌袋 steribag	纸箱 Box
供应商名称 Supplier Name	+	+
产品名称 Product Name	+	+
产品批号 Batch Number	+	+
产品数量 Quantity	+	+
生产日期 Manufacturing Date	+	+
有效期至 Expiry Date	+	+
灭菌方式 Type of sterilization	+	+

注：“+”表示标识该信息，“-”表示未标识该信息。

Note: "+" indicates that the information is identified, and "-" means that the information is not identified.

本产品应在室温下（10°C-30°C）储存。

This product should be stored at room temperature (10°C-30°C).

我公司按照 T/CNPPA 3017-2021《塑料和橡胶类药包材自身稳定性研究指南》对本产品进行长期试验和加速试验，以评估产品的自身稳定性，暂定本产品有效期为 3 年。

Tofflon conducts long-term tests and accelerated tests on this product in accordance with T/CNPPA 3017-2021 "Guidelines for Self-Stability Research of Plastic and Rubber Pharmaceutical Packaging Materials" to evaluate the self-stability of the product. The shelf life of this product is tentatively set at 3 years.

## 5. 产品符合性 Product Conformity

我公司按照中国药典指导原则、YBB00132004-2015、ISO 13926-1、USP<660>、EP 3.2.1 及 ISO 21881 等设定本产品质量标准并进行检验放行。

Tofflon sets product quality standards and inspects and releases the product in accordance with the general principles of the ChP, YBB00132004-2015, ISO 13926-1, USP<660>, EP 3.2.1 and ISO 21881.

本产品相容性研究按照《化学药品注射剂与药用玻璃包装容器相容性研究技术指导原则（试行）》、《化学药品与弹性体密封件相容性研究技术指导原则（试行）》及 ICH Q3D 执行。

The compatibility study of this product is conducted in accordance with the "Technical Guidelines for the Compatibility Study of Chemical Drug Injections and Medicinal Glass Packaging Containers (Trial)", "Technical Guidelines for the Compatibility Study of Chemical Drugs and Elastomer Lids (Trial)", and ICH Q3D.

## 6. 质量保证 Quality Assurance

我公司按照《药品生产质量管理规范》、《药包材生产质量管理规范》和 ISO 15378 药包材质量管理体系要求等法规标准建立、保持并持续改进我们的质量管理体系，以确保持续提供符合规定且质量稳定的产品和服务。

Tofflon establishes, maintains and continuously improves our quality management system in accordance with regulations and standards such as "Good Manufacturing Practice for Pharmaceutical Manufacturing", "Good Manufacturing Practice for Pharmaceutical Packaging Materials" and ISO 15378 *Primary packaging materials for medicinal products-Particular requirements for the application of ISO 9001:2015, with reference to good manufacturing practice(GMP)* to ensure that we continue to provide products and services that meet the requirements and have controllable quality.

本产品符合以下法规及标准要求：

This product complies with the following regulations and standards:

- 中国药典《笔式注射器用卡式瓶系统指导原则》；
- ChP Guideline on Cartridge system for pen-injectors
- 中国药典 9622《药用玻璃容器指导原则》；
- ChP 9622 Guideline on Glass Containers for Pharmaceutical Packaging
- 中国药典《药品包装用橡胶密封件指导原则》
- ChP 9623 Guideline on Rubber Closures for Pharmaceutical Packaging
- YBB00132004-2015《笔式注射器用硼硅玻璃套筒》；
- YBB00132004-2015 Borosilicate Glass Barrels for Pen-injector
- YBB00162004-2015《笔式注射器用溴化丁基橡胶活塞和垫片》
- YBB00162004-2015 Bromobutyl Rubber Plunger and Liner for Pen-injector
- ISO 13926 Pen systems
- USP<660> Containers-Glass
- EP 3.2.1 Glass containers for pharmaceutical use

- ISO 21881 Sterile packaged ready for filling glass cartridges

我公司采取以下措施，从设计上控制本产品质量：

Tofflon takes the following measures to control the quality of this product from the design:

- 采购已在上市药品中使用多年的原材料；
- Procurement of raw materials that have been used in marketed drugs for many years
- 套筒经清洗后，通过隧道烘箱进行烘干并去除热原；
- After the barrel is washed, it is dried in a tunnel oven and pyrogen is removed
- 产品清洗烘干后的轧盖至内包装工序在 C 级背景下的 A 级洁净环境中进行，最大限度地控制产品微粒、细菌内毒素和微生物污染；
- After drying process, the capping and primary packaging is carried out in a Class A clean environment in Class C background, so as to control the product particles, bacterial endotoxins and microbial contamination to the greatest extent
- 生产线上配置了多个在线外观检测装置，第一时间剔除不良品；
- The production line is equipped with multiple appearance inspection devices to reject defective products at the first time;
- 采用全自动运线，杜绝人为差错。
- Automatic transportation line is adopted to eliminate human error.

我公司按照中国药典《药包材检验规则指导原则》和 GB/T 2828 (idt.: ISO 2859) 制定本产品检验项目的检验规则和质量水平，如下表。

Tofflon formulate the inspection rules and Acceptance Quality Limit of the product inspection items in accordance with the ChP "Guiding Principles for the Inspection Rules of Pharmaceutical Packaging Materials" and GB/T 2828 (idt.: ISO 2859), as shown in the following table.

中硼硅玻璃套筒要求 Requirements of Barrel

检验项目 Items	接受标准 Acceptance criteria	缺陷等级 分类 Defect grade classification	是否批 检验 Batch inspection?	检验水 平 Inspection level	接收质量 限 (AQL)
外观 Appearance	本品应为无色透明或棕色透明；本品表面应光滑平整、无可见玻璃缺陷；本品所有部位应无裂纹。 It should be colorless and transparent or brown and transparent; The surface should be smooth and flat, without obvious glass defects; No part shall have cracks.	随机性缺陷 A 类 Random Defect A	是 Yes	I	0.4
线热膨胀系数 Linear thermal expansion coefficient	$(3.5 \sim 6.1) \times 10^{-6} \text{K}^{-1}$ (20~300°C)	系统性缺陷 Systemic Defect	否 No	N/A	N/A

检验项目 Items	接受标准 Acceptance criteria	缺陷等级 分类 Defect grade classification	是否批 检验 Batch inspection?	检验水 平 Inspection level	接收质量 限 (AQL)
三氧化二硼 含量 Boron trioxide content	≥8%	系统性缺 陷 Systemic Defect	否 No	N/A	N/A
尺寸 Dimension	应符合质量标准规定 Should meet the requirements of quality standard	随机性缺 陷 A 类 Random Defect A	是 Yes	S-2	0.4
121°C 玻璃颗 粒耐水性 121°C glass particle water resistance	应符合 1 级 Should comply with Level 1	随机性缺 陷 A 类 Random Defect A	否 No	N/A	N/A
内表面耐水 性 Internal surface water resistance	应符合 HC1 级 Should comply with HC1 level	随机性缺 陷 A 类 Random Defect A	否 No	N/A	N/A
砷、锑、 铅、镉浸出 量 As, Sb, Pd and Cd leachable amounts	每升浸出液中砷不得过 0.1mg、锑 不得过 0.7mg、铅不得过 1.0mg、镉 不得过 0.25mg As NMT 0.1mg, Sb NMT 0.7mg, Pd NMT 1.0mg, Cd NMT 0.25mg	系统性缺 陷 Systemic Defect	否 No	N/A	N/A
内应力 Internal stress	退火后的最大永久应力造成的光程 差不得过 40nm/mm The optical path difference caused by the maximum permanent stress after annealing shall not exceed 40nm/mm	随机性缺 陷 A 类 Random Defect A	是 Yes	S-2	0.4
耐热性 Heat resistance	不得破裂 Do not break	随机性缺 陷 A 类 Random Defect A	是 Yes	S-3	0.4
玻璃颗粒测 试 Glass Grains Test	每克供试品消耗的盐酸滴定液 (0.02mol/L) 的体积不得过 0.1ml。 Volume of 0.02 M HCl per g of Test Glass ≤ 0.1ml	N/A	N/A	N/A	N/A
内表面耐水 性 Surface Glass Test	应符合质量标准规定 Should comply with quality standard	N/A	N/A	N/A	N/A
砷浸出量 As leachable	≤0.1μg/g	N/A	N/A	N/A	N/A

## 活塞要求 Requirements of Plunger

检验项目 Items	接受标准 Acceptance criteria	缺陷等级 分类 Defect grade classification	是否批 检验 Batch inspection?	检验水 平 Inspection level	接收质量 限 (AQL)
外观 Appearance	本品表面色泽应均匀，不得有污点、杂质、气泡、裂纹、缺胶、粗糙、胶丝、胶屑、海绵、毛边；不得有除边造成的缺陷或锯齿现象；不得有模具造成的明显痕迹 The color of this product should be uniform, and there should be no stains, impurities, bubbles, cracks, lack of glue, roughness, rubber wire, rubber crumbs, sponges, and burrs; There shall be no defects or jagged phenomena caused by edge removal; There must be no obvious marks during molding.	随机性缺陷 B 类 Random Defect B	是 Yes	I	0.65
尺寸 Dimension	应符合质量标准规定 Should meet the requirements of quality standard	随机性缺陷 A 类 Random Defect A	是 Yes	S-2	0.4
红外光谱 Infrared spectrum	红外图谱均应与典型图谱基本一致 The infrared spectrum should be basically consistent with the typical spectrum	系统性缺陷 Systemic Defect	否 No	N/A	N/A
灰分 Ash	标称值±2% Nominal value±2%	系统性缺陷 Systemic Defect	否 No	N/A	N/A
挥发性硫化物 Volatile sulfides	不得深于标准硫斑 Not be deeper than standard sulfur spots (1.0µg/cm <sup>2</sup> )	系统性缺陷 Systemic Defect	否 No	N/A	N/A
不溶性微粒 Insoluble particles	≥10µm 的微粒数: ≤60 粒/ml; ≥25µm 的微粒数: ≤6 粒/ml ≥10µm particle NMT 60 /ml ≥25µm particle NMT 6 /ml	随机性缺陷 A 类 Random Defect A	是 Yes	N/A	N/A
细菌内毒素 BET	<0.25EU/ml	随机性缺陷 A 类 Random Defect A	是 Yes	N/A	N/A
无菌 Sterility	应符合规定 Be compliance	随机性缺陷 A 类 Random Defect A	是 Yes	N/A	N/A

## 活塞溶出物要求 Extractables test of Plunger

检验项目 Items	接受标准 Acceptance criteria	缺陷等级 分类 Defect grade classification	是否批 检验 Batch inspection?	检验水 平 Inspection level	接收质量 限 (AQL)
澄 清 度 与 颜 色 Clarity and color	供试液应澄清无色。如显浑浊，与 0.5 号浊度标准液比较，不得更浓。如显色，与黄绿色 5 号标准比色液比较，不得更深。 The test solution should be clear, any turbidity produced should be not more intense than turbidity standard solution No.0.5.The test solution should be colorless, any color observed should be not more intense than yellow-green No. 5 standard colorimetric solution.	N/A	N/A	N/A	N/A
pH 变化值 pH change value	供试液与空白液 pH 值之差不得过 1.0 The difference between the pH value of the test solution and the blank solution shall not exceed 1.0				
吸光度 Absorbance	在波长 220~360nm 范围内最大吸光度应≤0.1 The maximum absorption value between 220 and 360nm shall not exceed 0.1.				
易氧化物 Oxidizable substance	供试液与对照液消耗硫代硫酸钠滴定液 (0.01mol/L) 体积之差不得过 3.0mL The difference in volume between the consumed sodium thiosulfate titrant (0.01mol/L) of the test solution and the control solution should not exceed 3.0mL.				
不挥发物 Nonvolatile matter	供试液与空白液遗留残渣之差不得过 2.0mg The difference between the residue left by the test solution and the blank solution should not exceed 2.0mg				
电导率 Electrical conductivity	≤20.0μS/cm				
铵离子 Ammonium ion	与对照液目视比色，不得更深 (0.0002%) Compared with the control solution visually, it should not be darker (0.0002%)				
重金属 Heavy metals	供试液中重金属含量不得过百万分之一 ≤1ppm				
锌离子 Zinc ion	供试液应不得深于对照液。(0.0003%) Compared with the control solution				

检验项目 Items	接受标准 Acceptance criteria	缺陷等级 分类 Defect grade classification	是否批 检验 Batch inspection?	检验水 平 Inspection level	接收质量 限 (AQL)
	visually, it should not be darker (0.0003%)				

## 笔式注射器用卡式瓶系统要求 Requirements of Assembly

检验项目 Items	接受标准 Acceptance criteria	缺陷等级 分类 Defect grade classification	是否批检 验 Batch inspection?	检验水 平 Inspection level	接收质量 限 (AQL)
硅油量 The amount of silicone oil	应符合质量标准规定 Should comply with quality standard	随机性缺 陷 A 类 Random Defect A	是 Yes	N/A	N/A
密封性 Liquid leakage	应无穿过活塞或垫片的液体泄漏 There should be no liquid leakage through the plunger or liner	随机性缺 陷 A 类 Random Defect A	是 Yes	S-3	0.4
自密封性 Self- closure integrity	垫片穿刺部位应无液体泄漏 There should be no liquid leakage at the liner puncture site	随机性缺 陷 A 类 Random Defect A	是 Yes	S-3	0.4
穿刺落屑 Puncture chips	不得过 3 粒 ≤3 chips	随机性缺 陷 A 类 Random Defect A	是 Yes	N/A	N/A
滑动性能 Gliding performance	启始力≤10N 最大滑动力≤7N 平均滑动力≤4N Break loose force:≤10N Max. during gliding:≤7N Average during gliding:≤4N	随机性缺 陷 B 类 Random Defect B	是 Yes	S-2	0.4
不溶性微粒 Insoluble particles	≥10μm 的微粒: 不得过 60 粒/瓶; ≥25μm 的微粒: 不得过 6 粒/瓶 ≥10μm particle NMT 600 /cartridge ≥25μm particle NMT 60 /cartridge	随机性缺 陷 A 类 Random Defect A	是 Yes	N/A	N/A
细菌内毒素 BET	<0.25EU/ml	随机性缺 陷 A 类 Random Defect A	是 Yes	N/A	N/A
无菌 Sterility	应符合规定 Be compliance	随机性缺 陷 A 类 Random Defect A	是 Yes	N/A	N/A

## 7. 修订历史 History

版本号 Version	修订日期 Date	变更描述 Description
01	2024.07.09	新文件 New document
02	2025.02.07	修订滑动力接受标准 Revised the acceptance criteria for gliding performance
03	2025.08.05	增加英文版本 Add English translation

## 8. 附件 Drawing

- 8.1. 附件一：笔式注射器用卡式瓶系统（组装铝盖） Drawing 1: Cartridge with Cap 3ml
- 8.2. 附件二：卡式瓶巢板 3ml Drawing 2: Nest 3ml
- 8.3. 附件三：巢盒 Drawing 3: Tub
- 8.4. 附件四：产品装箱示意图 Drawing 4: Box packaging
- 8.5. 附件五：产品堆码示意图 Drawing 5: Pallet stacking
- 8.6. 附件六：笔式注射器用硼硅玻璃套筒 3ml Drawing 6: Glass Barrel 3ml
- 8.7. 附件七：笔式注射器用含垫片铝盖 Drawing 7: Aluminium Cap with Liner
- 8.8. 附件八：笔式注射器用溴化丁基橡胶活塞 Drawing 8: Plunger

1	2	3	4
版本VERSION	修订标记 REVISION	修订说明REVISION CONTENT	修订人 REVISER 修订日期 REVISION DATE

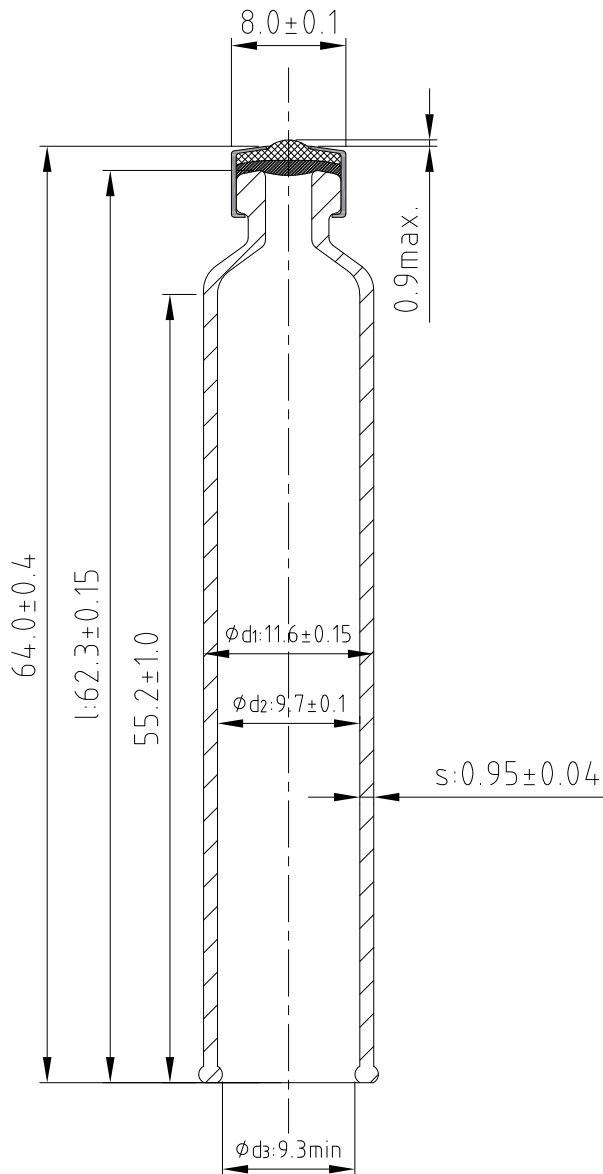

<b>Tofflon</b> 东富龙		此图纸版权属于东富龙所有，对未经许可擅自拷贝、使用者，本公司保留追究其法律责任的权利。 THIS DRAWING IS COPYRIGHT. IT MUST NOT BE COPIED, REPRODUCED OR OTHERWISE MADE USE OF WITHOUT THE TOFFLON'S WRITTEN PERMISSION.	
标题/TITLE: 笔式注射器用卡式瓶系统 (3ml) - 组装铝盖 Cartridge system for Pen-injector (assembled with Cap) 3ml		页/SHEET: 1 共/OF: 1	图幅/SIZE: A4_CN
客户名/CUSTOMER:		图号/DWG: TZ-TFL-1081-01	版本/REV: 01
设计/DESIGNED: ZZQ	日期/DATE: 2025.07.22	项目号/PROJECT NUMBER:	
审核/CHECKED:	日期/DATE:	未注明公差表 TOLERANCED UNLESS OTHERWISE NOTED	
日期/DATE: 2025.07.22	质量/MASS:	比例/SCALE: 2:1	MACHINING 机加工
材料/MATERIAL: N/A			WELDING 焊接
			SHEET METAL 钣金
			GB/T 1804-m GB/T 1184-K
			GB/T 19804-B GB/T 19804-F
			GB/T 15055-m

1 2 3 4 5 6 7 8

版本	修订标记	修订说明	修订人	修订日期

A

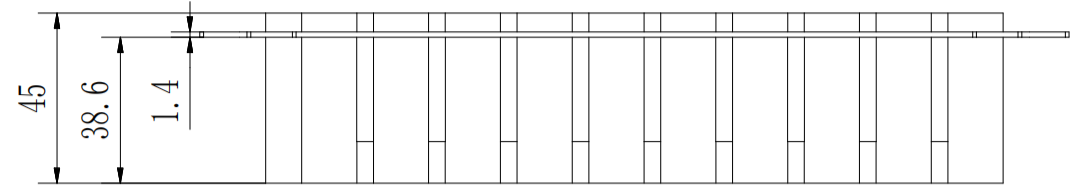

B

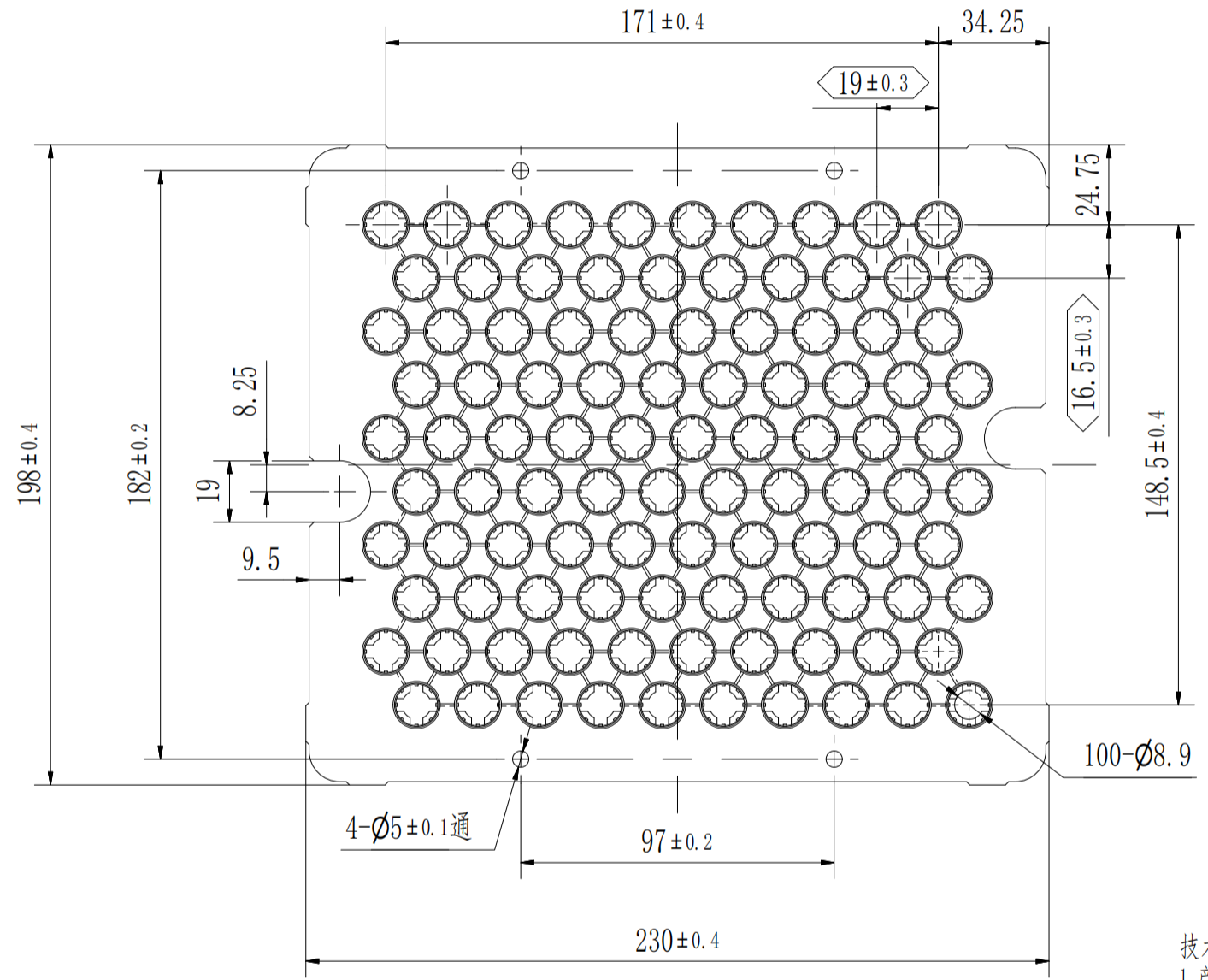

C

D

E

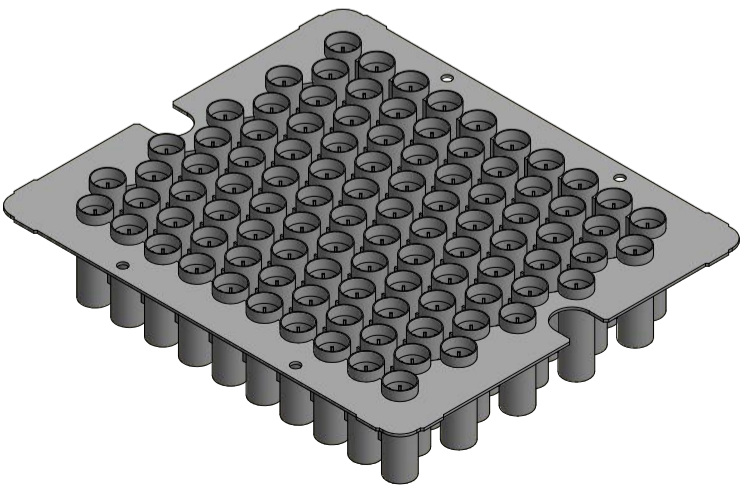

F

技术要求:

1. 产品内外表面应清洁, 无异物
2. 表面平整, 不得有缩水、划痕、冷却不良、变形等现象。无目视可见的残缺、杂质、毛刺等

<b>Tofflon 东富龙</b>		此图纸版权属于东富龙所有, 对未经许可擅自拷贝、使用者, 本公司保留追究其法律责任的权利。 THIS DRAWING IS COPYRIGHT. IT MUST NOT BE COPIED, REPRODUCED OR OTHERWISE MADE USE OF WITHOUT THE TOFFLON'S WRITTEN PERMISSION.	
标题/TITLE:		页/SHEET: 2 共/OF: 2	图幅/SIZE: A3
3ml 卡式瓶巢板 (100)		图号/DWG: TZ-TFL-1042-02	
客户名/CUSTOMER:		项目号/PROJECT NUMBER:	
设计/DESIGNED: WL	日期/DATE: 2023/4/7	质量/MASS:	未注明公差表 TOLERANCED UNLESS OTHERWISE NOTED
校核/CHECKED: SQ	日期/DATE: 2023/4/7	比例/SCALE: 1 : 2	
审核/APPROVED: ZJW	日期/DATE: 2023/4/7	材料/MATERIAL: PP	
		机加工 MACHINING	焊接 WELDING
		GB/T 1804-m GB/T 1184-K	钣金 SHEET METAL GB/T 19804-B GB/T 19804-F
			GB/T 15055-m

1 2 3 4 5 6 7 8

1	2	3	4
版本	修订标记	修订说明	修订人

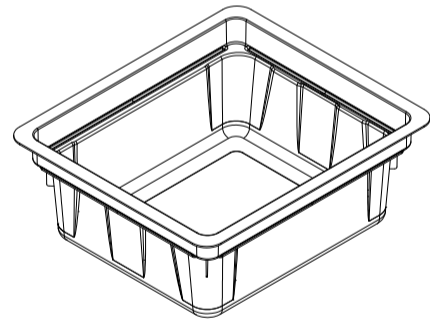
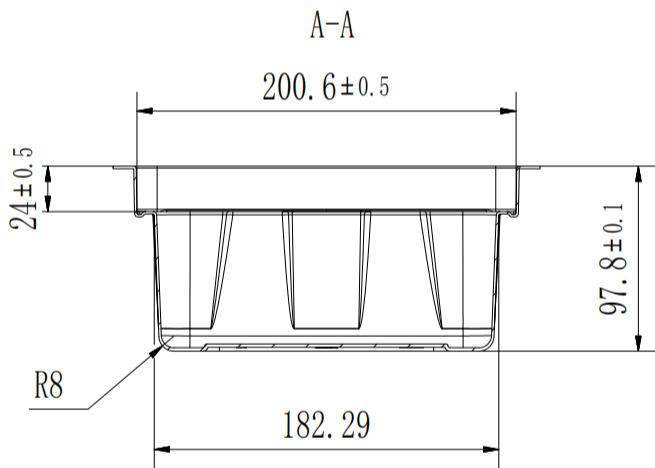
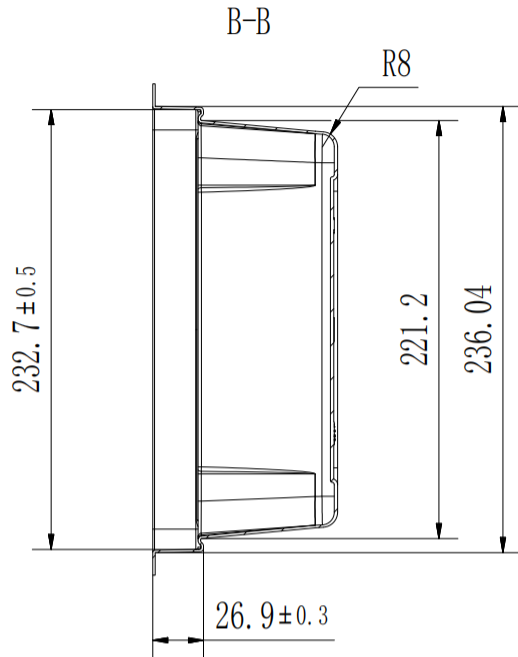
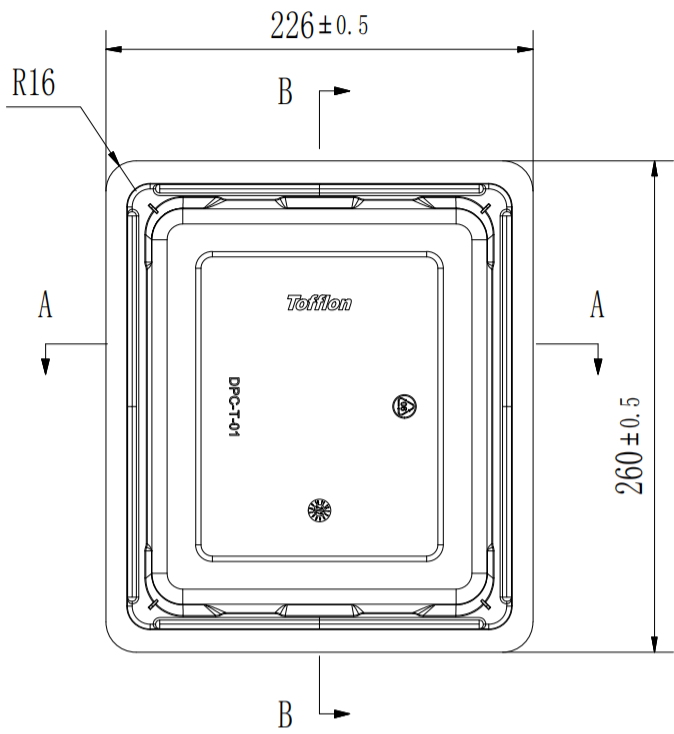

技术参数:

1. 产品内外表面应清洁, 无明显异物。
2. 表面平整, 不得有划伤、冷却不良、变形等现象。无目视可见的残缺、杂质、毛刺等

**Tofflon** 东富龙

此图纸版权属于东富龙所有, 对未经许可擅自拷贝、使用者, 本公司保留追究其法律责任的权利。  
THIS DRAWING IS COPYRIGHT. IT MUST NOT BE COPIED, REPRODUCED OR OTHERWISE MADE USE OF  
WITHOUT THE TOFFLON'S WRITTEN PERMISSION.

标题/TITLE:

巢盒

页/SHEET: 1 共/OF: 1 图幅/SIZE: A4

图号/DWG: TZ-TFL-1044-01

版本/REV:

01

客户名/CUSTOMER:

项目号/PROJECT NUMBER:

设计/DESIGNED: wanglei

日期/DATE: 2023/06/12

质量/MASS:

未注明公差表  
TOLERANCED UNLESS OTHERWISE NOTED

校核/CHECKED: SQ

日期/DATE: 2023/06/12

比例/SCALE: 1 : 4



机加工  
MACHINING

焊接  
WELDING

钣金  
SHEET METAL

审核/APPROVED: ZJW

日期/DATE: 2023/06/12

材料/MATERIAL: PS

GB/T 1804-m  
GB/T 1184-K

GB/T 19804-B  
GB/T 19804-F

GB/T 15055-m

1	2	3	4
版本	修订标记	修订说明	修订人 修订日期

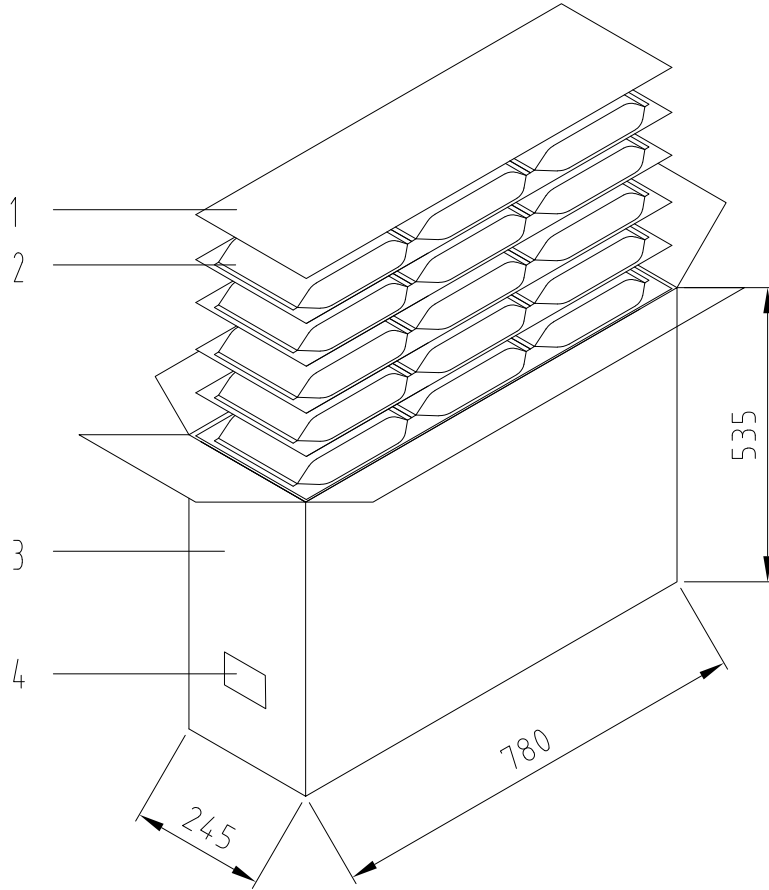

序号	详细信息
1	隔板
2	双层呼吸袋包装并封口的产品
3	五层瓦楞纸箱
4	纸箱标签

<b>Tofflon</b> 东富龙		此图纸版权属于东富龙所有，对未经许可擅自拷贝、使用者，本公司保留追究其法律责任的权利。 THIS DRAWING IS COPYRIGHT. IT MUST NOT BE COPIED, REPRODUCED OR OTHERWISE MADE USE OF WITHOUT THE TOFFLON'S WRITTEN PERMISSION.	
标题/TITLE: 巢盒包装产品装箱示意图 (15)		页/SHEET: 1 共/OF: 1	图幅/SIZE: A4_CN
客户名/CUSTOMER:		项目号/PROJECT NUMBER:	
设计/DESIGNED: ZX	日期/DATE: 2023.12.20	未注明公差表 TOLERANCED UNLESS OTHERWISE NOTED	
校核/CHECKED:	日期/DATE:	比例/SCALE: 1:13	机加工 焊接 钣金
审核/APPROVED: SYT	日期/DATE: 2023.12.20	材料/MATERIAL: N/A	GB/T 1804-m GB/T 1184-K
			GB/T 19804-B GB/T 19804-F
			GB/T 15055-m

版本	修订标记	修订说明	修订人	修订日期

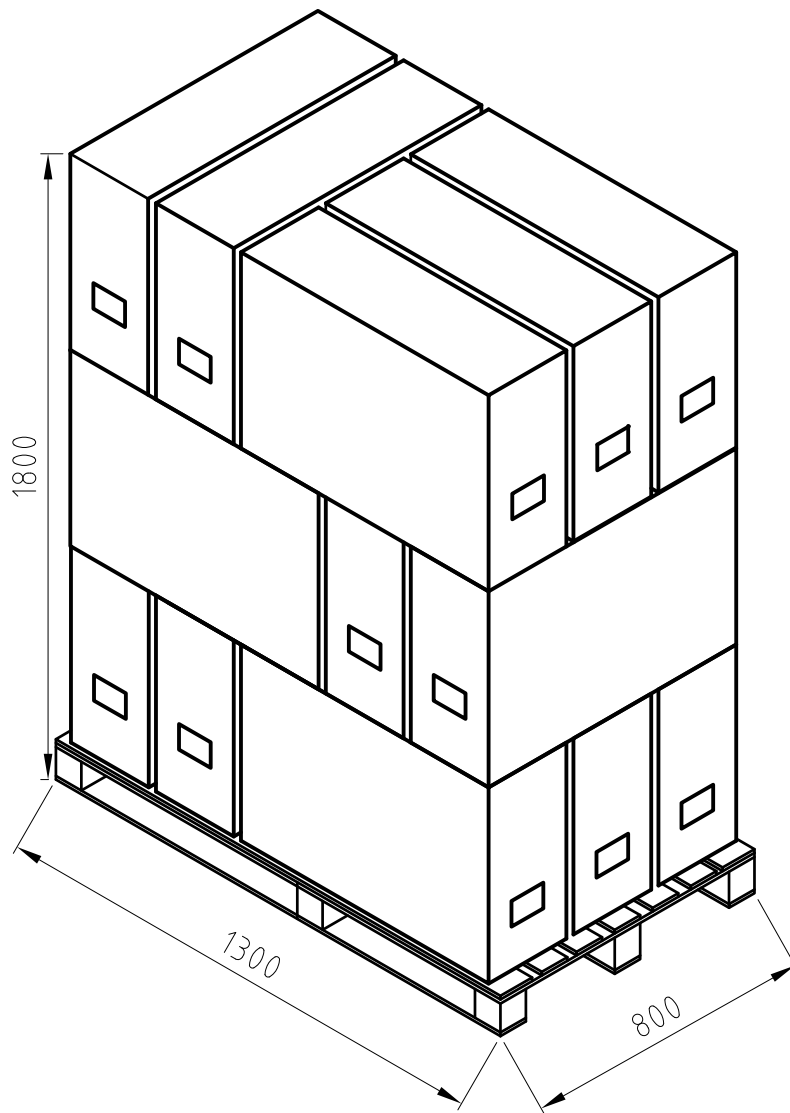

**Tofflon** 东富龙

此图纸版权属于东富龙所有，对未经许可擅自拷贝、使用者，本公司保留追究其法律责任的权利。  
THIS DRAWING IS COPYRIGHT. IT MUST NOT BE COPIED, REPRODUCED OR OTHERWISE MADE USE OF  
WITHOUT THE TOFFLON'S WRITTEN PERMISSION.

标题/TITLE:

巢盒包装产品堆码示意图

页/SHEET: 1 共/OF: 1

图幅/SIZE: A4\_CN

图号/DWG:

TZ-TFL-3004-01

版本/REV:

01

客户名/CUSTOMER:

项目号/PROJECT NUMBER:

设计/DESIGNED: ZX

日期/DATE: 2023.12.20

质量/MASS:

未注明公差表  
TOLERANCED UNLESS OTHERWISE NOTED

校核/CHECKED:

日期/DATE:

比例/SCALE: 1:20

机加工

MACHINING  
机加工

WELDING  
焊接

SHEET METAL  
钣金

审核/APPROVED: SYT

日期/DATE: 2023.12.20

材料/MATERIAL: N/A

GB/T 1804-m  
GB/T 1184-K

GB/T 19804-B  
GB/T 19804-F

GB/T 15055-m

版本VERSION	修订标记 REVISION	修订说明REVISION CONTENT	修订人 REVISER	修订日期 REVISION DATE

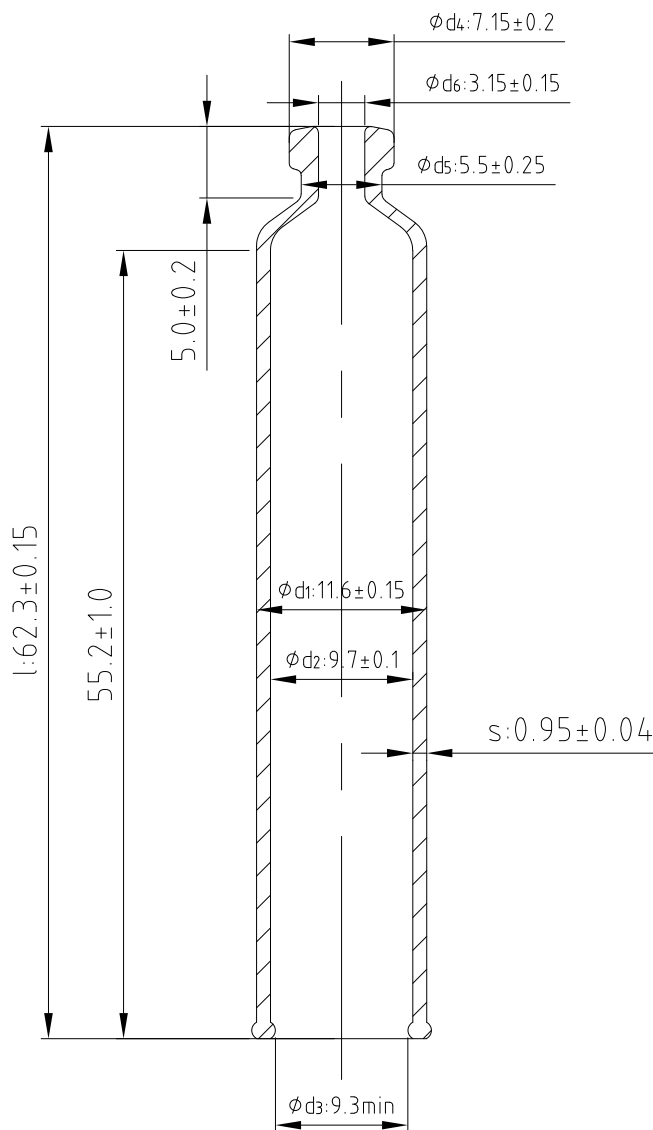

<b>Tofflon</b> 东富龙		此图纸版权属于东富龙所有，对未经许可擅自拷贝、使用者，本公司保留追究其法律责任的权利。 THIS DRAWING IS COPYRIGHT. IT MUST NOT BE COPIED, REPRODUCED OR OTHERWISE MADE USE OF WITHOUT THE TOFFLON'S WRITTEN PERMISSION.		
标题/TITLE: <b>笔式注射器用硼硅玻璃套筒 (3ml)</b> Cartridge 3ml		页/SHEET: 1 共/OF: 1	图幅/SIZE: A4_CN	
		图号/DWG: TZ-TFL-2034-01		版本/REV: 01
客户名/CUSTOMER:		项目号/PROJECT NUMBER:		
设计/DESIGNED: ZX	日期/DATE: 2025.02.12	质量/MASS:	未注明公差表 TOLERANCED UNLESS OTHERWISE NOTED	
校核/CHECKED: WJY	日期/DATE: 2025.02.12	比例/SCALE: 2:1	MACHINING 机加工	WELDING 焊接
审核/APPROVED: MZ	日期/DATE: 2025.02.12	材料/MATERIAL: 中硼硅玻璃 Medium borosilicate glass	GB/T 1804-m GB/T 1184-K	SHEET METAL 钣金 GB/T 15055-m

1	2	3	4
版本VERSION	修订标记 REVISION	修订说明 REVISION CONTENT	修订人 REVISER 修订日期 REVISION DATE

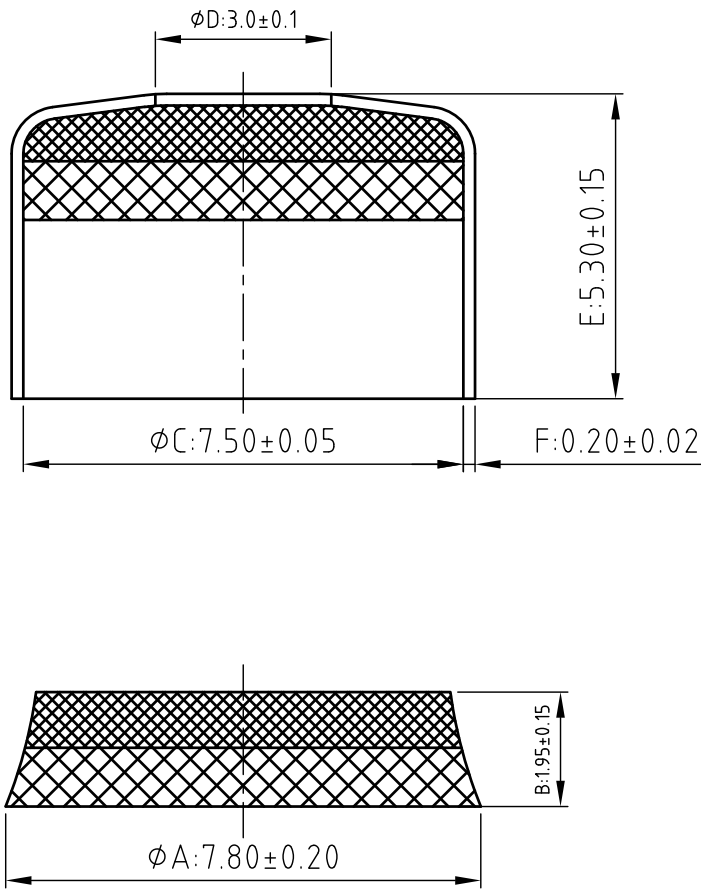

### 技术要求 Technical Requirements:

1. 本品由橡胶垫片和铝盖两部分组成，垫片为双层垫片，分别为聚异戊二烯橡胶和卤化丁基橡胶

**This product is composed of two parts: rubber gasket and aluminum cover, and the gasket is a double-layer gasket, which is polyisoprene rubber and halobutyl rubber.**

2. 内外表面应清洁，无残留溶剂、毛刺和损伤 **The inner and outer surfaces should be clean and free of residual solvents, burrs, and damage.**

<b>Tofflon</b> 东富龙		此图纸版权属于东富龙所有，对未经许可擅自拷贝、使用者，本公司保留追究其法律责任的权利。 THIS DRAWING IS COPYRIGHT. IT MUST NOT BE COPIED, REPRODUCED OR OTHERWISE MADE USE OF WITHOUT THE TOFFLON'S WRITTEN PERMISSION.							
标题/TITLE: <b>笔式注射器用含垫片铝盖</b> Aluminum Cap with Gasket for Pen-injector		页/SHEET: 1 共/OF: 1	图幅/SIZE: A4_CN						
客户名/CUSTOMER:		项目号/PROJECT NUMBER:	图号/DWG: TZ-TFL-2035-01						
设计/DESIGNED: ZX	日期/DATE: 2025.01.10	质量/MASS:	版本/REV: 01						
校核/CHECKED: WJY	日期/DATE: 2025.01.10	比例/SCALE: <b>8:1</b>	未注明公差表 TOLERANCED UNLESS OTHERWISE NOTED						
审核/APPROVED: MZ	日期/DATE: 2025.01.10	材料/MATERIAL: <b>Al+Rubber</b> 铝/橡胶	<table border="1"> <tr> <td>MACHINING 机加工</td> <td>WELDING 焊接</td> <td>SHEET METAL 钣金</td> </tr> <tr> <td>GB/T 1804-m GB/T 1184-K</td> <td>GB/T 19804-B GB/T 19804-F</td> <td>GB/T 15055-m</td> </tr> </table>	MACHINING 机加工	WELDING 焊接	SHEET METAL 钣金	GB/T 1804-m GB/T 1184-K	GB/T 19804-B GB/T 19804-F	GB/T 15055-m
MACHINING 机加工	WELDING 焊接	SHEET METAL 钣金							
GB/T 1804-m GB/T 1184-K	GB/T 19804-B GB/T 19804-F	GB/T 15055-m							

版本 VERSION	修订标记 REVISION	修订说明 REVISION CONTENT	修订人 REVISER	修订日期 REVISION DATE

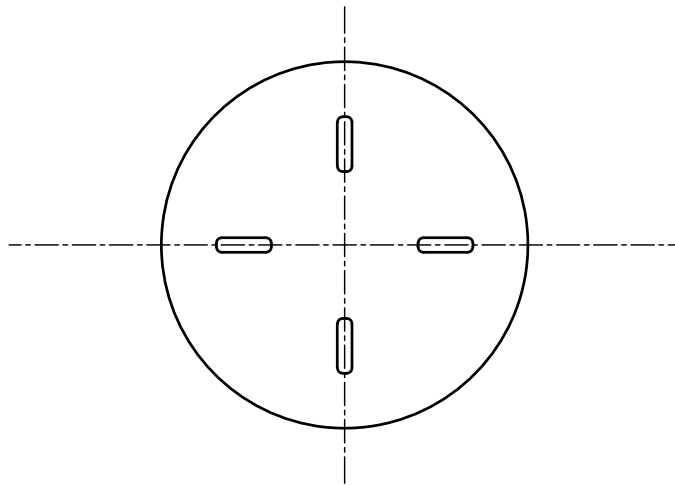
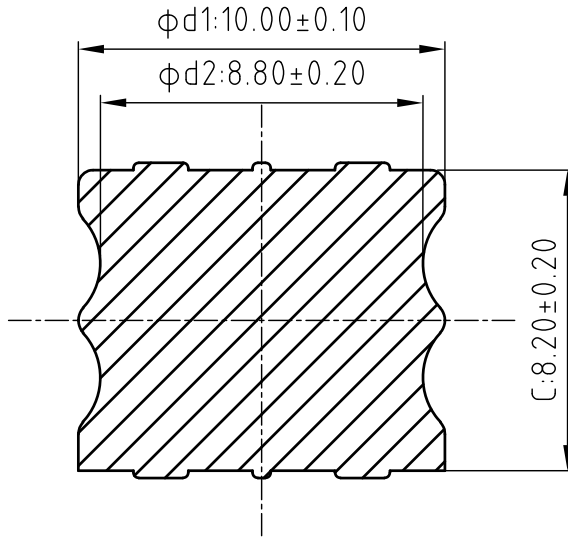

The dimensions of this product comply with ISO 13926-2:2017

<b>Tofflon</b> 东富龙		此图纸版权属于东富龙所有，对未经许可擅自拷贝、使用者，本公司保留追究其法律责任的权利。 THIS DRAWING IS COPYRIGHT. IT MUST NOT BE COPIED, REPRODUCED OR OTHERWISE MADE USE OF WITHOUT THE TOFFLON'S WRITTEN PERMISSION.		
标题/TITLE: BROMOBUTYL RUBBER PLUNGERS FOR PEN-INJECTORS(3ML)		页/SHEET: 1 共/OF: 1	图幅/SIZE: A4_CN	
客户名/CUSTOMER:		图号/DWG: TZ-TFL-1048-01		版本/REV: 01
设计/DESIGNED: ZX		日期/DATE: 2024.04.12	项目号/PROJECT NUMBER:	
校核/CHECKED:		日期/DATE:	质量/MASS:	
审核/APPROVED: SYT		日期/DATE: 2024.04.12	比例/SCALE: <b>5:1</b>	
材料/MATERIAL: BROMOBUTYL RUBBER		未注明公差表 TOLERANCED UNLESS OTHERWISE NOTED		
		MACHINING 机加工	WELDING 焊接	SHEET METAL 钣金
		GB/T 1804-m GB/T 1184-K	GB/T 19804-B GB/T 19804-F	GB/T 15055-m